

Northern Arizona University

Wind Turbine Technical Report
Submitted to: US Department of Energy
April 21, 2019



NORTHERN
ARIZONA
UNIVERSITY

Collegiate Wind Competition 2019

Mechanical Design Tunnel Team:

Riley Sinek (Blade & Pitching Design)
Tanner Lehr (Brake, Nacelle, & Tower Design)
Naser Alrashidi (Shaft Design)
Faisal Alrashidi (Yaw-Tail Design)

Faculty Mentors:

David Willy (Principle Advisor and Mechanical Technical Advisor)

DISCLAIMER

This report was prepared by students as part of a university course requirement. While considerable effort has been put into the project, it is not the work of licensed engineers and has not undergone the extensive verification that is common in the profession. The information, data, conclusions, and content of this report should not be relied on or utilized without thorough, independent testing and verification. University faculty members may have been associated with this project as advisors, sponsors, or course instructors, but as such they are not responsible for the accuracy of results or conclusions.

EXECUTIVE SUMMARY

The project explores a practical approach to designing a wind turbine for the Collegiate Wind Competition that will be staged in Boulder, Colorado in May. It aligns to the Customer Requirements (CRs) defined by the United Nation's Department of Energy that foster cost effectiveness, compactness of a design, durability and stellar efficiency for any new wind turbine system. Besides the stated engineering requirements stated below in Section 2.2, the project entails the discussion of testing procedures that examine parameters such as cut-in speeds, yaw rate, the yield strength of the system, fatigue strength and house of quality. Among the existing designs include projects from the 2017 competition that are functionally the same but adopt varying system designs. The selected designs incorporate improved stepper motor and lead screw brake system, a linear actuator braking system that is equipped with a smaller blade on a roll chair tower design. Notably, the best design was picked by leveraging a Pugh chart for a series of decision matrices. Finally, the proposed design, which compensates for the loss of length in the distance off the rear of the system. Increased yaw on the vertical distance and the orientation of the intercepts of the two ends of the yaw section.

1 Table of Contents

1	BACKGROUND	7
1.1	Introduction	7
1.2	Project Description.....	7
1.3	Original System	7
1.3.1	Original System Structure	8
1.3.2	Original System Operation.....	8
1.3.3	Original System Performance	8
1.3.4	Original System Deficiencies.....	8
2	REQUIREMENTS.....	8
2.1	Customer Requirements (CRs).....	8
2.2	Engineering Requirements (ERs).....	9
2.3	Testing Procedures.....	9
2.3.1	Cut-in Speed.....	10
2.3.2	Yaw Rate	10
2.3.3	Yield Strength.....	10
2.3.4	Fatigue Strength	10
2.4	House of Quality (HoQ)	10
3	EXISTING DESIGNS	10
3.1	Design Research.....	11
3.2	System Level	11
3.2.1	Existing Design #1: NAU CWC '17	11
3.2.2	Existing Design #2: PSU CWC '17.....	12
3.2.3	Existing Design #3: NAU CWC '18.....	12
3.3	Functional Decomposition.....	13
3.3.1	Black Box Model	13
3.3.2	Functional Model	14
3.4	Subsystem Level.....	14
3.4.1	Subsystem #1: Blade Design	15
3.4.2	Subsystem #2: Yaw Design.....	15
3.4.3	Subsystem #3: Brake Design	17
3.4.4	Subsystem #4: Shaft designs.....	17
3.4.5	Subsystem #5: Tower	19

4	DESIGNS CONSIDERED	20
4.1	Design #1: Stepper Motor with Lead Screw Brake	20
4.2	Design #2: Linear Actuator Braking System	21
4.3	Design #3: Small Blade	21
4.4	Design #4: Wide Base Blade	22
4.5	Design #5: Roll Chair Tower Design.....	22
4.6	Design #6: CWC '18 tower design	22
4.7	Design #7: Yaw Incorporated Tower Design.....	22
4.8	Design #8: Angled Pyramid Scheme Yaw Design	23
4.9	Design #9: Hollow Shaft Design	23
4.10	Design #10: Thick Diameter Ends Shaft Design	24
5	DESIGNS SELECTED – First Semester	24
5.1	Rationale for Design Selection.....	24
5.1.1	Blade Design Selection.....	24
5.1.2	Brake Design Selection	25
5.1.3	Tower Design Selection	26
5.1.4	Yaw Design Selection.....	27
5.1.5	Shaft Design Selection	27
5.2	Design Description	27
5.2.1	Blade Design.....	28
5.2.2	Brake Design	28
5.2.3	Wide base Tower Design	29
5.2.4	Angled Yaw Design:	30
5.2.5	Hollow Shaft Design.....	31
6	Proposed Design.....	32
7	Design Objectives - Second Semester.....	34
7.1	Aerodynamics design objectives.....	35
7.2	Brake Design Objectives	35
7.3	Structure Design Objectives	35
7.4	Yaw Design Objectives	35
8	Basic Static Performance(Not Included)	36
9	Analysis of Mechanical Loads.....	36
9.1	Blade Analysis	36

9.2	Hub Analysis.....	37
9.3	Shaft Analysis.....	38
9.4	Brake Analysis.....	39
9.5	Tower Analysis.....	40
9.6	Yaw Analysis.....	41
9.7	Nacelle Analysis.....	42
10	REFERENCES.....	43
11	11 APPENDICES.....	44
11.1	11.1 Appendix A: House of Quality.....	44
11.2	11.2 Appendix B: Designs Considered.....	44
11.3	11.3 Appendix C: Designs Selected.....	46

List of Figures

Figure 3.1	NAU CWC '17.....	12
Figure 3.2	PSU CWC '17.....	12
Figure 3.3	NAU CWC '18.....	13
Figure 3.4	Black Box Model.....	13
Figure 3.5:	Functional Model.....	14
Figure 3.6	ABM Greiffenberger.....	16
Figure 3.7	700 TW Yaw.....	16
Figure 3.8	700T Yaw.....	17
Figure 3.9	Wind-Turbine Shaft (HS-0018).....	18
Figure 3.10	Turbine Generator Shaft Rs 1.25 Lakh.....	18
Figure 3.11	Guoguang Rotor Shaft.....	18
Figure 3.12	Hybrid Tower Design.....	19
Figure 3.13	Lattice Tower.....	19
Figure 3.14	Steel Tabular Tower.....	20
Figure 4.1	Stepper Motor with Lead Screw Brake.....	21
Figure 4.2	Small Blade Concept.....	22
Figure 4.3	Angled Pyramid Yaw.....	23
Figure 4.4	Hollow Shaft Design.....	23
Figure 5.1	Brake Assembly.....	29
Figure 5.2	CAD Drawing of Tower.....	29
Figure 5.3	Isometric View of Yaw.....	31
Figure 5.4:	Side View of Yaw.....	31
Figure 5.5	Hollow Shaft Design.....	32
Figure 6.1	Wind Turbine Final Proposed Design.....	33
Figure 9.1	Blade FEA.....	37

Figure 9.2 Hub Stress FEA	38
Figure 9.3 Hub Claw FEA	38
Figure 9.4 Shaft	39
Figure 9.5 Front Brake Caliper FEA.....	39
Figure 9.6 Back Brake Caliper FEA.....	40
Figure 9.7 Brake Disc FEA.....	40
Figure 9.8 Tower FEA.....	41
Figure 9.9 Tail FEA Analysis.....	42
Figure 9.10 Nacelle FEA	42

List of Tables

Table 2.1 Engineering Requirements	9
Table 5.1 Blade Pugh Chart.....	25
Table 5.2 Blade Design Decision Matrix	25
Table 5.3 Brake Design Pugh Chart	26
Table 5.4 Brake Design Decision Matrix	26
Table 6.1 CWC '19 Budget.....	34

?

ACRONYMS

1. CRs - Customer Requirements
2. ERs - Engineering Requirements
3. HoQ – House of Quality
4. HAWTs – Horizontal Axis Wind Turbines
5. VAWTs - Vertical Axis Wind Turbines
6. RC – Remote Control
7. NAU – Northern Arizona University
8. PSU – Penn State University
9. CWC – Collegiate Wind Competition
10. USDOE – United States Department of Energy
11. FEA – Finite Element Analysis

1 BACKGROUND

1.1 Introduction

Renewable energy is a growing industry across the globe especially in developing economies. The sector of energy is constantly expanding because there is a desire to live in a clean world while attempting to reverse the detrimental environmental impacts such as pollution and reports of global warming that prior generations have caused. A leading technology in the renewable energy sector is the implementation of wind turbines into the existing grid. Wind turbines are designed in such a way that wind can be harnessed and transformed from kinetic energy into electrical energy. Our team will design a wind tunnel scale turbine that will have its performance presented and tested by our team at the United States Department of Energy's (USDOE) Collegiate Wind Competition. The United States Department of Energy sponsors the competition, which involves many tunnel tests and a siting challenge as a part of the competition. Furthermore, the USDOE facilitates the role of colleges in preparing students to enter the wind energy workforce by offering real-world technology experience. The Tunnel Team will consist of a mechanical and electrical design teams to develop a power producing wind tunnel wind turbine.

1.2 Project Description

Each year, the United States Department of Energy hosts the Collegiate Wind Competition. This competition plays host to twelve schools each year, in different locations throughout the United States each year, testing each school's best effort at manufacturing a wind turbine to produce electrical energy. The 2019 competition will be held in Boulder, Colorado in May. Throughout the three-day competition, each team's wind turbine will endure a variety of tests, pushing the turbine to its limits, while being judged throughout each test. Our team will be the fifth team to represent Northern Arizona University at the Collegiate Wind Competition this upcoming May. The turbine must meet the rules and regulations stated by the U.S. Department of Energy, including the compactness and efficiency of the developed wind turbine design.

"The challenge in 2019 will call on students to research, design, and enhance a turbine for a grid scenario with a high concentration of renewables and be able to operate in an islanded mode," says USDOE.

1.3 Original System

The NAW CWC competition has been graced by several wind turbine designs since its launch in 2014 by the UNDOE. The project has limited its analysis to a few designs that excelled in 2017 and 2018. The merits and demerits of previous proposals are key to devising and fabricating an improved design that aligns to as most engineering and customer requirements as possible. However, it should be noted that the similarities examined during the assessment exercise should not be ignored as they shed more light in the design process.

1.3.1 Original System Structure

Previous teams devised wind turbines based on a horizontal axis wind turbine (HAWT) approach. The 2017 and 2018 teams also leveraged carbon fiber materials when constructing the blades. Up to four blades were used. additional design elements included the use of a single-pad disk brake to manage the speed of the blades. Permanent magnet AC generators were used alongside DC-DC converters.

1.3.2 Original System Operation

Previous designs and implementation were run on fixed blades that transformed wind energy into electric energy by powering generators. Electrical energy was transformed from mechanical energy that turned the generator's shaft. The generator produced active current that regularized DC output. The electronics parts of the design were held on a breadboard.

1.3.3 Original System Performance

The 2017 design was able to generate more than 24 watts of power using wind speed of approximately 12 m/s. What is more, the tip speed ratio was approximately 2 at varying wind speeds. Generally speaking, the aim of the experiment is to devise a wind turbine mechanism that can generate more power under the same or improved wind speed conditions.

1.3.4 Original System Deficiencies

Original designs have been unable to address increased amounts of cog torque that lead to the production of more lift at during when the system is powered. Friction in some of the system components has been attributed to cogging torque.

2 REQUIREMENTS

In this chapter, all the customer requirements, engineering requirements and testing procedures are given by the Department of Energy will be listed. Engineering requirements were created to correspond to each of the customer requirements. The two sets of criteria were compiled into a house of quality, which can be found in Appendix A.1. The lists were compared against each other to quantify the importance of each element of this project.

2.1 Customer Requirements (CRs)

The guidelines for the Collegiate Wind Competition (CWC), which include CRs and associated rules are sourced for the USDOE. Some constraints were present as described by our David Willy, our faculty advisor. David stated that it was necessary to extensively examine the CRs when compiling the points. These requirements were specific, and did not leave much room for interpretation, therefore the

weights of many of the listed requirements are listed at their max value. Nevertheless, below, the list of requirements and a quick description are listed, along with their rated level of importance on a scale of 1-5.

1. Cost Effective: The overall budget must be under \$3000 when including supplies for testing and prototyping.
2. Optimize Efficiency: The wind turbine should gather the maximum kinetic energy possible from the wind. Weighted 4/5.
3. Effective Direction Mechanism: The wind turbine should be able to yaw into the direction of changing wind in order to always achieve maximum efficiency. The yawing mechanism must achieve a designated rotation rate for the wind turbine. Weighted 5/5.
4. Robust Start-up: The wind turbine should cut in within a designated range of wind speeds. The earlier the rotor begins spinning, the earlier the power generating process begins. Weighted 5/5.
5. Strong: The turbine must withstand up to the maximum wind speed and respond to all forces acting at any given point in time without failure. Weighted 3/5.
6. Durable: The wind turbine will be undergoing many cycles between testing and the competition, due to its rapid moving parts. The turbine components must withstand a high number of fluctuating loading throughout its lifespan. Weighted 3/5.
7. Lightweight: To obtain a high-level of efficiency and allow for one person to comfortably transport the turbine, it must balance strength and weight. Lightweight moving parts of the turbine will reduce loading stress throughout the turbine and allow for one person to move the machine with ease. Weighted 2/5.
8. Portable: When traveling to competition the wind turbine will need to be taken apart and stored to make sure nothing will be damaged. Weighted 2/5.

2.2 Engineering Requirements (ERs)

The engineering requirements were gathered from the Department of Energy Rule book for this competition. Each of the customer requirements stated above are also related to engineering requirements. The Table below is also complemented by ERs such as performance coefficient that describes the power of the turbine to overcome wind, compactness and weight of system, its rated power for the selected generator and drag coefficient to generate lift for the blade. Reliability should also be robust.

Table 2.1 Engineering Requirements

Engineering Requirements	Target Value
Minimize Cost	\$3000
Volume	45x45x45 cm^3
Cut-in Speed	2.5 – 5 $\frac{m}{s}$
Yaw Rate	$\leq 180^\circ$
Access Area	61 x 121 cm^2
Number of Cycles to Failure	107 cycles
Weight	40lbs
Assembly Time	10 min

2.3 Testing Procedures

Testing procedures have been described to ensure that the engineering requirements are met without issue. Many of the engineering requirements require no testing, and simply a measurement phase, and therefore will be left out of this section. After assembly, the team will have a large amount of time in the second semester to test and reiterate on the turbine design.

2.3.1 Cut-in Speed

The cut-in speed of the turbine is the lowest wind speed that the wind turbine begins to produce power. To verify that the cut-in speed is within 2.5-5 m/s, the team will use an anemometer to determine the free stream speed inside a wind tunnel. Additionally, we will be testing with the electrical team who can determine when the ultra-capacitor begins receiving a charge.

2.3.2 Yaw Rate

Our team will be testing is a mount that is identical to the mount we will see at the competition. The test will be performed inside the wind tunnel. The mount has rotational range that we can control throughout testing. Our team can determine the yawing rate of our wind turbine by using a dynamometer aimed at our baseplate during a rotational phase. Additionally, the team can aim the dynamometer at the nacelle to determine the relationship of yaw rate and rotation rate of the baseplate at various wind speeds.

2.3.3 Yield Strength

By competition standards, our turbine's tower must be able to withstand 50 N-m worth of applied bending moment. After thorough calculations, our team will simply apply a determined force and a specific point simulate 50 N-m to the turbine tower.

2.3.4 Fatigue Strength

The team will obtain data on the material that is decided on when designing the shaft in detail. Due to time constraints, our team does not plan on testing the shaft until failure. The team will use the data obtained to determine a factor of safety for the shaft at any point on the shaft.

2.4 House of Quality (HoQ)

The house of quality was used to compile customer and engineering requirements in such a way that the two sets of requirements could be evaluated against each other. The requirements were then weighted based on their correlation. Using this process, a final list of most important engineering characteristics of the project was created for the benefit of the team throughout the design process. According to Appendix 1.1, the examination includes tabling customer requirements against engineering requirements and assessing their weighting. The results are given based on ratings over 40. It should be noted that the ratings of CRs are according to importance that presents variables that can be leveraged to satisfy both CRs and ERs.

3 EXISTING DESIGNS

As renewable energy continues to grow as a source of producing power, wind turbines are constantly being innovated to be more efficient in harnessing kinetic energy from the wind and converting it into electrical energy. Windmills have been used for centuries as “work machines” being used as mills to process wheat into flour, as well as other uses. To meet the demands of power needed in the modern age, wind turbines were evolved into power production machines. The primary turbines seeing use today are horizontal and vertical axis wind turbines (HAWTs and VAWTs, respectively). Chapter 3: Existing Designs will outline the background research done by the team that was necessary to find the proper approach to designing a wind turbine.

3.1 Design Research

Overall, the primary research for this wind turbine project was done by examining previous designs for their pros and cons prior to developing new approaches that can improve them. Initially, the benchmarking process began online, finding designs that have been tested in previous collegiate wind competitions. As most teams are recurring participants in the competition, it was difficult to gain access to documents relating to previous competition teams, as they are trying to protect their intellectual property. Fortunately, the 2017 competition team for Penn State University made their reports available, allowing our team to benchmark against a consistently strong competitor. The examination of previous CWC designs benchmarked several designs from 2017 and 2018.

After online benchmarking gave the team few results, our process turned to our next medium for research. This next step was the hand-on portion requested by David Willy. Professor Willy met with our team twice, explaining how the competition works and how past NAU teams have fared. Throughout these couple meetings, he made clear to us what concepts had strong potential of working and what component did not work for teams in the past. At the adjournment of our third meeting with David Willy, we were given NAU’s 2018 competition turbine to disassemble, analyze, and reassemble.

3.2 System Level

Our team completed research on past competition wind turbine teams to maintain relevance to the project. The predominant design that teams in the past have used is a three-bladed, passive yawing design. The components of each of these turbines operate on small scale due to the size requirement, and coincidentally, many turbine components are the same scale as hobbyist remote control (RC) vehicles. It was not uncommon to see RC components being used in test turbine designs throughout our benchmarking process. Each of our three benchmarked turbines can be found in Figures 3.1, 3.2, and 3.3; NAU CWC ’17, PSU CWC ’17, and NAU CWC ’18, respectively.

3.2.1 Existing Design #1: NAU CWC ’17

The NAU wind turbine that was built to compete in the 2017 Collegiate Wind Competition featured a design that used four-blades, an open nacelle, and an acrylic passive yawing mechanism [1]. The turbine used a four-blade design to achieve a high solidity in the swept area without creating blades with an unusual chord length. The acrylic yaw ultimately did not work for the team on the first day of the competition, so the team revamped the design in the hotel the first night to feature a two-tail wooden yaw to produce the yawing torque necessary to steer the turbine into the wind effectively. The two-tail wooden yaw performed better than the original single-tailed acrylic tail. The team ultimately did well in their competition, and therefore provides a strong design for reference in designing our own turbine.



Figure 3.1 NAU CWC '17

3.2.2 Existing Design #2: PSU CWC '17

The Penn State University (PSU) wind turbine for the 2017 competition implemented a couple different components that NAU turbines have not yet included. Blade design for this turbine was especially eccentric and performed well, scooping the top spot in the 2017 competition. The blades were designed in a way to overcome the high torque requirements in accordance with the generator team's design [2]. The team achieved this by optimizing the solidity and keeping a blade number of three to find the balance of rpm and torque requirements. In addition, as PSU teams have done frequently, an active pitching mechanism was implemented into their design to avoid aerodynamic hysteresis and accomplish cutting-in at a low wind speed.



Figure 3.2 PSU CWC '17

The pitching mechanism was designed in such a way that the blades could be controlled throughout the testing duration to maintain an optimum angle of attack, and therefore avoid stalling. On the electrical side, an axial flux generator was selected due to its low cogging torque. Additionally, the axial flux generator can produce consistent power at high rpm as well. The combination of these two criteria allowed the turbine to cut-in at low wind speeds and maintain power production at high rpms after reaching the rated wind speed for the turbine. The turbine performed well, earning the top overall design award, winning the competition for 2017. Using this design as a benchmark provides our team knowledge on what top performing designs have looked like in the history of the CWC.

3.2.3 Existing Design #3: NAU CWC '18

The wind turbine that was built to represent NAU's 2018 Collegiate Wind team implemented a three-bladed, two tail yaw design. The design performed well enough to earn sixth out of twelve teams competing during the most recent wind competition held. The blades were designed to have a long chord length, which causes them to appear thick in Figure 3.3. The chord length under analysis was used to achieve a high solidity in a different way than the 2017 NAU team attempted. The design featured a linear

actuator with an RC rotary brake set as the braking system. The linear actuator provided sufficient power to stop the rotor from spinning without much difficulty [3]. While braking the turbine was not an issue, releasing the brakes to allow the turbine to cut-in again was an issue. Several linkages were used as an effort to transfer the translational motion from the actuator to the brake pad. Furthermore, the brake system was inaccurate and challenging to control because of several unnecessary linkages. Using a linear actuator is a feasible solution to braking if it is implemented in such a way that the linear actuator is connected to the braked pad mechanism with no more than one linkage. The comparison of the design has allowed our team to iterate upon a high potential turbine. The turbine would have finished in the top three speed out of ten if their brake system had not failed.

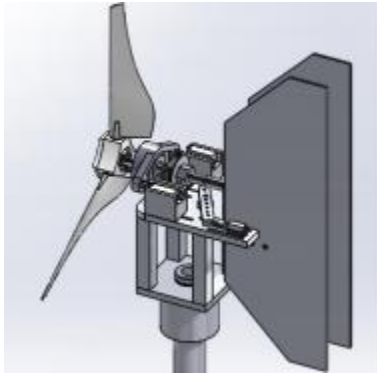

Figure 3.3 NAU CWC '18

3.3 Functional Decomposition

The start of the design process begins with understanding the scenario at hand. In this chapter, the evaluation of all components is described and listed in a concrete manner. The activity of generating hypotheses for the project can only be pursued once the design has been fabricated, tested and presented. Nevertheless, by formulating a hypothesized decomposition of the testing turbine, our team can devote its resources to gather resources required for the project. To this end, the goal of decomposing the scenario is to ultimately gather information to formulate a focused plan to follow.

3.3.1 Black Box Model

The first step of decomposing the situation that the wind turbine will experience is to express the process in a general form. This general form will create a scope on what enters and exits the system. In Figure 3.4, the inputs and outputs of the system are listed with inputs and outputs of the model are broken into three categories: Material, Energy, and Signal.

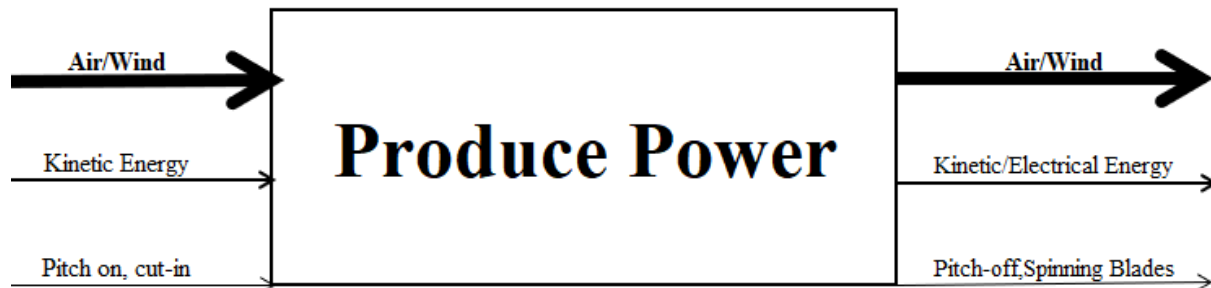

Figure 3.4 Black Box Model

As the input and output, air is the primary driving concern for the wind turbine. The mass flow rate of the wind will be what causes the turbine to begin moving. The wind turbine will convert kinetic energy from the wind into electrical energy, which can be found on the second, medium-thickness line. The input material has mass which results in power produced. The signal input is more complicated than the inputs for material and energy. To properly operate the wind turbine, the blades must be pitched into the wind so that the rotor can cut-in (begin to spin). The signal output consists of similar outputs. The pitch is turned off to allow the blade to return to its normal operating state, while continuing to spin. The pitch and motion of the blades are considered signals because they are both visual verification that the turbine is operating for an observer. The inputs and outputs will result in the production of electrical power.

3.3.2 Functional Model

The functional model elaborates on the black box model, breaking down the operation of the test turbine, illustrating the process that the turbine will complete to achieve its purpose, producing power. The wind turbine is comprised of a variety of components, interacting with each other through many types of energy, as indicated in Figure 3.5. For the wind turbine to operate, there must be wind blowing, otherwise there is no kinetic energy to convert into electrical energy. The blades are designed in such a way that the wind imparts a lift force on the blades, resulting in rotation of the rotor system. A torque is imparted on the shaft, which rotates the generator. Rotating the generator is the goal of the turbine, so that power can be generated. The turbine must accomplish other tasks, that are listed as side branches from the main line of Figure 3.5: Functional Model. The purpose of the model is for the team to hypothesize each detail involved within the operation of the wind turbine. The goal of creating this model is to gather the importance of each step, and allowing the team

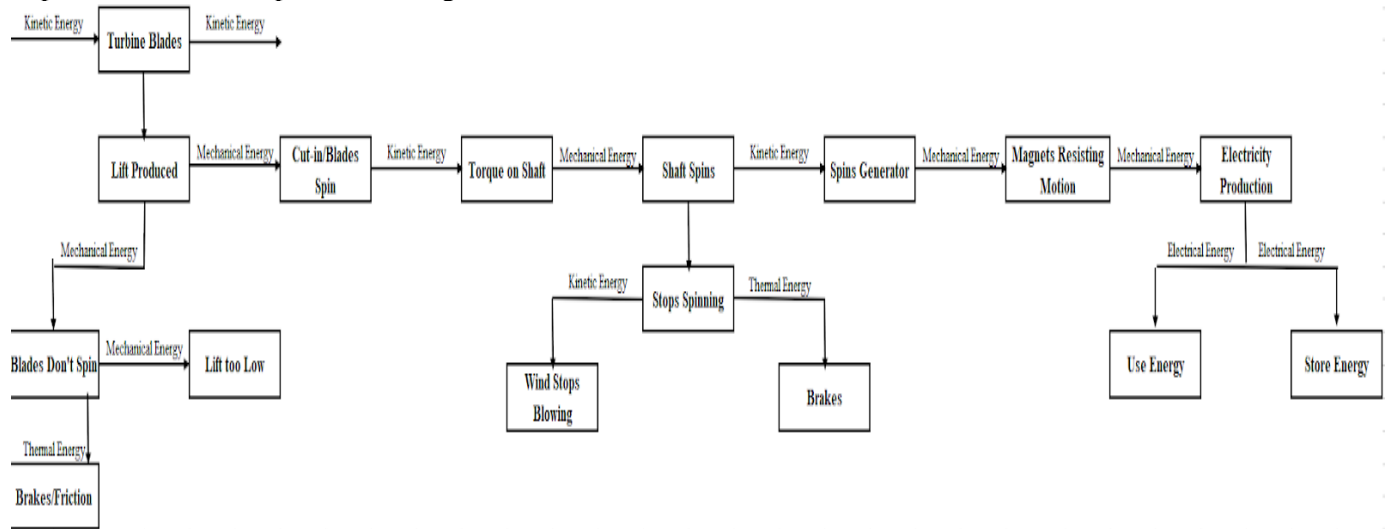

Figure 3.5: Functional Model

3.4 Subsystem Level

The turbine that the team is planning on building will consist of five different subsystems. Each subsystem in the machine will be necessary to operate the turbine.

3.4.1 Subsystem #1: Blade Design

Designing the blades of the turbine will be the most vital component of the design. To create the proper amount of lift to get the blades spinning. Getting the blades spinning requires an in-depth analysis of the incoming flow that the turbine will experience [4]. After converging on a flow solution, it will then be necessary to find the proper combination of airfoils and evaluate the airfoils in Q-Blade.

3.4.1.1 Existing Design #1: Betz Blade

The Betz Blade is a simplified model of blade analysis that only considers the Blade Element Momentum Theory. The flow considered is fully laminar. The model does not consider more complex components for modeling such as turbulence and wake [5]. Its simplicity and lightweight components imply that it requires fewer parts that can cut the budget of the project and optimizes efficiency by leveraging fewer complex tools.

3.4.1.2 Existing Design #2: ALTEMP Blade

NAU's Collegiate Wind Competition Team that competed in the 2017 competition used ALTEMP in creating their blades. This material is can be easily manufactured but does not provide the stiffness that other feasible blade materials will provide [5]. The material is a strong contender because it strikes the balance between cost and functionality. The blade meets cost effectiveness for the budget presented. The blade is also projected to increase the efficiency of the system.

3.4.1.3 Existing Design #3: Carbon Fiber Blade

Teams representing NAU have used carbon fiber blades in the past. Carbon fiber has properties that would have relevant properties to create the blade. Carbon Fiber is stiff and strong but tends to be more expensive than most other feasible options [7]. Due to advances in technology, 3D printing carbon fiber blades makes the concept of using the material much more financially feasible. Stiffness enhance efficiency and durability, which can allow the wind turbine to undergo several cycles before a component breaks or requires replacement.

3.4.2 Subsystem #2: Yaw Design

When a wind turbine has an appropriate yaw design, the direction of optimal wind will be achieved thus increasing efficiency of the wind turbine. When wind is at its optimum, the energy generated by the wind turbine is very high and this is mainly achieved when the yaw is focused on an optimal angle to the incoming wind hence making it to rotate in an effective manner thus leading to a high energy production. Three existing yaw designs are as discussed below.

3.4.2.1 Existing Design #1: ABM Greiffenberger Yaw

The new ABM Greiffenberger yaw drives has the ability of maintaining nacelle positions in the wind direction to maximize generation of energy. It has a combination of induction motors and multi-stage planetary gearboxes. The motors have an output range of 2.2 to 22 kW [6]. Drive systems have output torque ratings with a range of 2,000 to 50,000 Nm and maximum output torques of up to 100, 000 Nm [4].



Figure 3.6 ABM Greiffenberger

3.4.2.2 Existing Design #2: Yaw 700 TW

700 TW - Wind Turbine Yaw has output shafts which are supported by heavy duty bearings and has a high transmissible torque. It also has a high radial load capacity, high shock resistance, high efficiency, low weight and a wide range of reduction ratios ranging from 60 up to 3000 [5].



Figure 3.7 700 TW Yaw

3.4.2.3 Existing Design #3: 700T Yaw

700T series yaw design has the ability of limiting peak of torque hence avoiding instances of failure. It is externally placed in relation to the gear box and hence can be replaced with ease. It has the ability of shutting down the gearbox when torque limit is reached [6].



Figure 3.8 700T Yaw

3.4.3 Subsystem #3: Brake Design

The brake design must slow the wind turbine down to a complete stop at wind speeds up to 20 m/s. The system must be able to brake on command and be able to release the brake when the turbine must start back up.

3.4.3.1 Existing Design #1: Hydraulic Braking System

The first braking system uses hydraulics to activate the brakes. There have been few teams in past Collegiate Wind Competitions to use hydraulic brakes, but there are plenty of RC cars out there that use them, and they typically work well. Hydraulic brakes work by pushing a rod forward into hydraulic fluid which can push the fluid into the opposite end of a cylinder [5]. This design is strong and durable in a wind turbine application, but it is not very cost effective and can be hard to assemble.

3.4.3.2 Existing Design #2: Linear Actuator Braking System

NAU's 2018 Collegiate Wind Competition team used a linear actuator to activate the brakes. The linear actuator will use Arduino to tell the actuator to push the rod forward to activate the brakes or to bring the rod back to release the brakes. This design is very compact and is strong, but the one downside is the cost.

3.4.3.3 Existing Design #3: Dynamic Braking System

Collegiate Wind Competition teams in the past have used dynamic braking system. This design uses the generator on the wind turbine to create a resistive torque on the system [7]. To create a resistive torque a relay will be used to short the system. For this system to work, a generator with a kV rating between 100-200 would work the best. A kV rating is the amount of revolutions per minute (rpm) per open circuit voltage. Dynamic braking is cost effective because a generator is already needed to capture energy in the system, but a downside to this design is at high wind speeds they are proven to be unreliable.

3.4.4 Subsystem #4: Shaft designs

The shaft is a crucial component of the wind turbine since it is responsible for spinning the generator to produce electricity. Three shaft designs have been described below.

3.4.4.1 Existing Design #1: Wind-Turbine-Shaft (HS-0018)

This shaft is characterized by high strength since it is made up of steel. It has low porosity and long service life. However, it is expensive [7]. It is presented in the figure below.



Figure 3.9 Wind-Turbine Shaft (HS-0018)

3.4.4.2 Existing Design #2: Turbine Generator Shaft Rs 1.25 Lakh

This shaft is characterized by high tensile stress hence it can withstand a lot of pressure and great loads. It is made of steel and can last for a long period of time. However, it is very expensive [8]. It is shown in the diagram below.



Figure 3.10 Turbine Generator Shaft Rs 1.25 Lakh

3.4.4.3 Existing Design #3: Guoguang rotor shaft

This shaft is characterized by high strength since it is made up of steel. This also facilitates durability of the design. The disadvantage is that it is expensive [8]. It is represented in the diagram below.



Figure 3.11 Guoguang Rotor Shaft

3.4.5 Subsystem #5: Tower

The tower of the wind turbine is very crucial since it supports all the other components of the wind turbine. Existing Tower designs are discussed in this section.

3.4.5.1 Existing Design #1: Hybrid Tower

It is comprised of a concrete tower which is mounted directly on the base at the location and then pre-stressed. The advantage of this is that the concrete tube is produced on site, hence reduction on transport cost. The entire system has an adequate resonance frequency as the diameter of the concrete element which is fitted in the lower part of the hybrid tower is adjustable.



Figure 3.12 Hybrid Tower Design

3.4.5.2 Existing Design #2: Lattice Tower

This design is characterized by a zigzag body made up of steel. The design makes the tower strong thus can withstand strong winds and load. It is appropriate for wind turbines with long and heavy blades. It is shown in the figure below.



Figure 3.13 Lattice Tower

3.4.5.3 Existing Design #3: Steel tubular tower

This tower design is made up of steel and hence it is strong and highly durable. It has a high level of ductility hence can handle large deformations. Also, it has a high tensile strength and can be easily fabricated [4]. It is as shown in the figure below.



Figure 3.14 Steel Tabular Tower

4 DESIGNS CONSIDERED

In this section concepts for each subsystem have been designed in accordance to customer and engineering requirements. The subsystems include brakes, blades, shaft, yaw, and tower design. Two designs for each subsystem is shown below, and the remaining designs can be found in Appendix B.

4.1 Design #1: Stepper Motor with Lead Screw Brake

In the first design, seen in figure 4.1, a stepper motor is being used to initiate the brakes when the wind turbine is spinning. When the turbine is required to brake, the stepper motor will turn the lead screw that is attached to a nut on the brake caliper which will cause the brake caliper to press against the rotor to stop the turbine. The main advantage of this braking system is that stepper motors are very accurate and can get to the same position repeatedly with very little variance. Another advantage is that stepper motors are cheap if you compare them to a linear actuator. The disadvantage for this system is that stepper motors tend to be bigger than linear actuators, so when designing the nacelle more space will need to be allocated to the design.

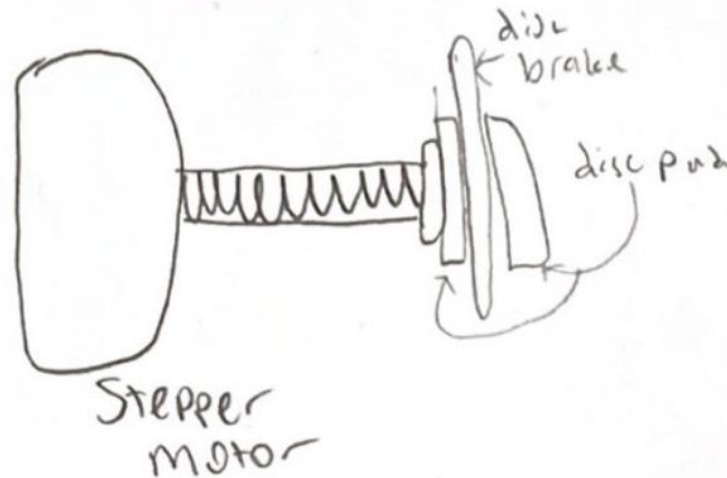

Figure 4.1 Stepper Motor with Lead Screw Brake

4.2 Design #2: Linear Actuator Braking System

The second brake design, shown in Appendix B.1, shows a linear actuator pushing the brake pad into the rotor disc. When braking is required, the linear actuator will be attached to the brake pad and move forward to apply pressure to the rotor disc. The main advantages to this system are that it is lightweight, has a small volume, and can apply an effective force. A big disadvantage to using a linear actuator is the cost.

4.3 Design #3: Small Blade

The first feasible concept considered for the blade concept generation was the small blade drawing concept. This thought considered a blade which would be much smaller than the maximum 45x45cm² cross-sectional swept area for the wind's entry to the system. This blade considers a strong factor in the performance of the blade, and that is the overall weight of the blade. The small blade concept would have the advantage of having an early cut-in wind speed due to the lack of material necessary to create blade rotation. The primary disadvantage to this design is that the rotor will not be optimized because the blades will be smaller than the largest possible swept area. The swept area of a turbine is a driving factor in a turbine's overall effectiveness. The original drawing of this concept can be found below in Figure 4.2: Small Blade Concept.

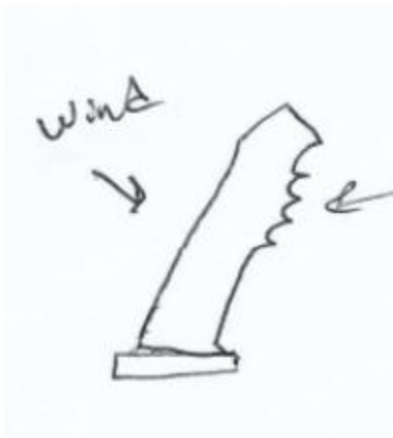

Figure 4.2 Small Blade Concept

4.4 Design #4: Wide Base Blade

The other most feasible blade concept was the wide base blade concept. The wide base concept implemented a blade that would lead to a higher solidity of blades, which is the ratio of blade material vs. empty space in the swept area by the rotor components. The higher solidity of the swept area generally results in a higher torque on the shaft, overcoming the resistive and cogging torques that the shaft will experience during start up. In addition, using a wide base blade will allow the blades to maintain consistent Reynold's Number operating conditions across the length of the blade. The disadvantages to using this blade concept are that the blade will need more material to make. Due to the extra material to make the blade, the weight will be increased leading to a more difficult time for the turbine to cut-in. Additionally, using more material means the wide base blade will be more expensive to manufacture than the small blade concept listed in the previous section. In Appendix B.2, the original concept drawing for the wide base blade is shown.

4.5 Design #5: Roll Chair Tower Design

The design resembles a rolling chair. Its major advantage is that it is lighter than a baseplate. Its major disadvantage is that it is not stable enough to withstand the wind. It also can move easily if the high wind hit the chair. It also does not meet competition requirements. What is more, it has been used across a variety of applications besides wind turbines, and the stated disadvantage is often present. While improved designs have been devised, the roll-chair tower design is popular, and can be leveraged to explain the design elements when developing a tower for the turbine whilst taking note of its shortcomings. This figure can be seen in Appendix B.3.

4.6 Design #6: CWC '18 tower design

The design gets its concept from the NAU '18 Collegiate Wind Competition tower design. Its major advantage is that it is stable and can be fastened to mount in the ground. It can resist pressure, tension and strong wind speeds.

4.7 Design #7: Yaw Incorporated Tower Design

The design mimics the tower. Its major advantage is that it would perform its purpose of a tower while also contributing to other components (yawing system) of the turbine. The disadvantages are that it has inefficient yawing power and too little surface area. This figure can be seen in Appendix B.4.

4.8 Design #8: Angled Pyramid Scheme Yaw Design

This design resembles a pyramid. Its major advantage is that it is compact, strong and has high efficiency. Its major con is that it is heavier than other potential yaws.

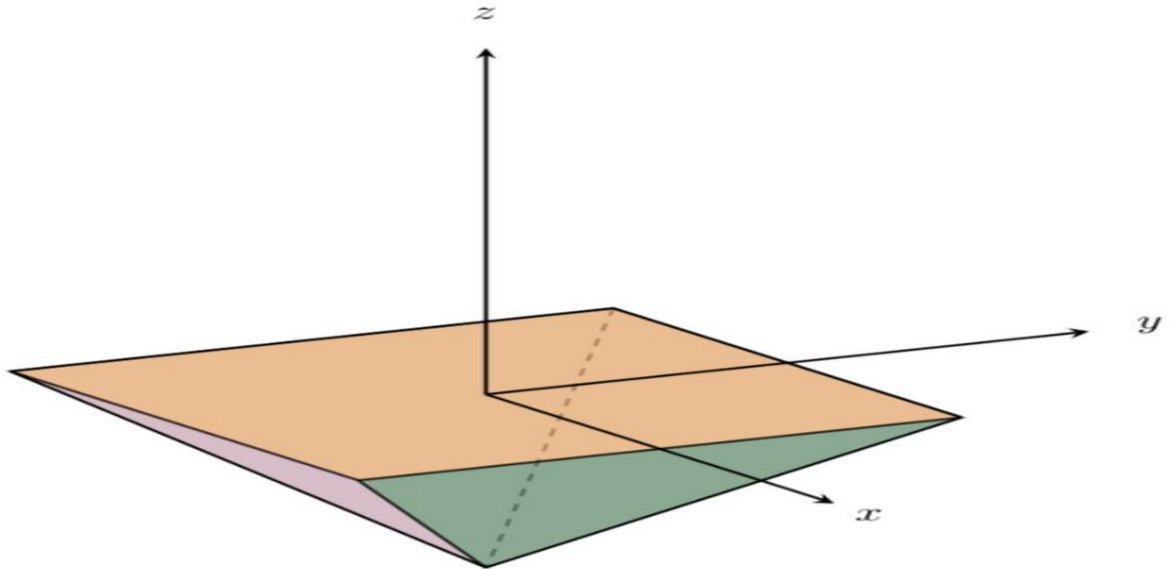

Figure 4.3 Angled Pyramid Yaw

4.9 Design #9: Hollow Shaft Design

The design has a tube which is hollow. Its major pros are a weight reduction concept and is easier to rotate. The major con is that it has a smaller cross-sectional area hence less durable.

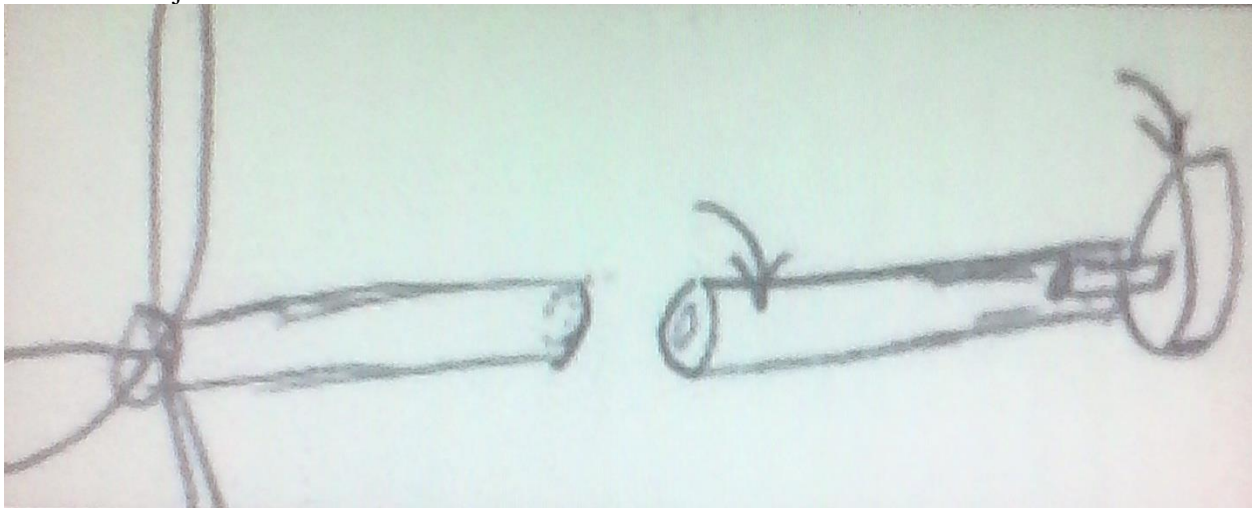

Figure 4.4 Hollow Shaft Design

4.10 Design #10: Thick Diameter Ends Shaft Design

The design entail ends which are thicker. Its major pro is larger cross-section which facilitates durability at concentrated stress points. Its cons are that it is heavier than necessary and has higher stress concentration at diameter changes. This design can be seen in Appendix B.5.

5 DESIGNS SELECTED – First Semester

Section 5 goes over the processes of selecting the best design for each subsystem. First, each design was put into a Pugh Chart and was narrowed down to the top three choices that were then put into a Decision Matrix. With the raw score for each design, the best design was chosen for each system.

5.1 Rationale for Design Selection

The team compiled potential designs into selection tools created by the team known as Pugh charts and decision matrices. The team used the Pugh charts to determine the most viable option for the designated subsystem. Each subsystem had its own Pugh Chart and Decision Matrix to determine the best concept for development. In Chapter 5.1, the results of the selection phase will be discussed and shown.

5.1.1 Blade Design Selection

A Pugh chart was used to evaluate the optimum blade concept that our team would use. In Table 5.1, the variation of blades that were conceptualized during the concept generation phase can be found. Furthermore, the selection process entails the evaluation factors that influence efficiency that may include a conglomeration of several multiple airfoil types. The dimensions of the parameters, which include definitions for compactness, durability and efficiency, to mention a few, are selected in a manner that encourages the reduction of the wind cut in speed. These blades were compared to a datum, which is the Betz Blade model. This datum is a simple blade model that ignores many factors that can impact blade performance but allows the team a simple conceptualization of turbine blades. In the Pugh chart, the team found that the wide bade blade would be the best candidate from our concepts generated, while the small blade concept would be the second most efficient/viable option. Lastly, the material selected for the blade can be tested using Q-Blade and FAST.

Table 5.1 Blade Pugh Chart

		Blade(s)				
		Betz Blade	Small Blade	Wide Base	Heavy Blade	Feather Blade
Concept	DATUM	2	3	4	1	
Criteria						
Cost Effective		+		-	-	
Optimize efficiency		-	+	+		
Compact		+				
Low Cut-in			+	-	-	
Strong			+	+	-	
Durable		-		+	-	
Lightweight		+	-	-	+	
Portable/ease of assembly						
# of +'s		3	3	3	1	
# of -'s		2	1	3	4	
Sum		1	2	0	-3	

After completing the Pugh Chart for the blade concepts, the team compiled the highest scores into a decision matrix. The decision matrix, shown in Table 5.2, showed our team that the best concept overall would be a wide based blade. Devoting energy to this design will allow our team to optimize the swept area of the blades, while also increasing solidity near the root. This increased solidity will increase the torque that the blade can impart around the shaft.

Table 5.2 Blade Design Decision Matrix

		Blade Design					
Criteria	Weight(%)	Small Blade		Betz Blade		Wide Base	
		Score	Weighted Score	Score	Weighted Score	Score	Weighted Score
Cost Effective	12.87%	65	8.3655	60	7.722	60	7.722
Optimize efficiency	7.63%	20	1.526	50	3.815	70	5.341
Compact	13.77%	60	8.262	50	6.885	50	6.885
Low Cut-in	13.32%	40	5.328	60	7.992	80	10.656
Strong	11.68%	50	5.84	60	7.008	70	8.176
Durable	11.80%	50	5.9	60	7.08	70	8.26
Lightweight	9.43%	70	6.601	50	4.715	45	4.2435
Portable/ease of assembly	10.70%	50	5.35	50	5.35	50	5.35
		SUM=	47.1725	SUM=	50.567	SUM=	56.6335

5.1.2 Brake Design Selection

In Table 5.1, the brake concepts were compared against customer requirements for the subsystem. Five concepts were compared against the datum, NAU's CWC '18 brake design. The design they used was a linear actuator design with a three-stage lever system to control a brake pad system with a floating rotor.

Table 5.3 Brake Design Pugh Chart

		Brake Design					
		CWC '18	Dynamic	Hydraulic	Stepper Motor	Brushless	Yaw Brake
Criteria	Concept	DATUM	1	2	3	4	5
Cost Effective				-	+	-	+
Optimize efficiency			-	-		-	-
Compact			+	-	-	-	
Low Cut-in							
Strong			-	+	+		+
Durable				+		-	
Lightweight			+	-	-	-	+
Portable/ease of assembly			+	-	+	-	-
# of +'s			3	2	3	0	3
# of -'s			2	5	2	6	2
Sum			1	-3	1	-6	1

After completing the Pugh chart for brake selection, it was found that dynamic braking, stepper motor actuation, and a yaw brake were the most viable concepts, all rating higher than the datum. These three designs were gathered into a decision matrix (Table 5.2) to determine the best overall brake concept. The Yaw brake concept was not a viable concept in practice, so it was not evaluated in the decision matrix. NAU's '18 brake design was then the third concept evaluated within the brake design decision matrix.

Table 5.4 Brake Design Decision Matrix

		Brake					
		CWC'18		Dynamic		Stepper Motor	
Criteria	Weight(%)	Score	Weighted Score	Score	Weighted Score	Score	Weighted Score
Cost Effective	12.87%	35	4.5045	80	10.296	75	9.6525
Optimize stopping power	7.63%	75	5.7225	40	3.052	80	6.104
Compact	13.77%	40	5.508	65	8.9505	50	6.885
Releasing Power	13.32%	15	1.998	60	7.992	70	9.324
Strong	11.68%	65	7.592	60	7.008	75	8.76
Durable	11.80%	50	5.9	50	5.9	75	8.85
Control	9.43%	60	5.658	50	4.715	70	6.601
Portable/ease of assembly	10.70%	5	0.535	60	6.42	45	4.815
	91.2%	SUM=	37.418	SUM=	54.3335	SUM=	60.9915

The concept that the team will invest further research and development in will be the stepper motor system. This system will use qualities of other systems, such as the floating rotor with brake pads, to complete its task.

5.1.3 Tower Design Selection

The same process was used again for the tower design subsystem. This subsystem supports the nacelle and its connected parts. In addition, the tower acts as housing for the electrical wires that leave the tunnel during testing. Lastly, the tower is the machine's only connection to the fastening plate. The tower's strength is essential to the safety and operation of the wind turbine. The Pugh chart and Decision matrix for the tower selection can be found in Appendix C.1 and C.2. The datum was NAU 2018's Tower Design, due to its strong performance in last year's performance and recommendation from our faculty advisor. The design was a simple pipe welded to a baseplate of the same material, which had slots cut out

of it to fasten to the competition mount. In the Pugh chart, our team compared our five best concepts against last year's team. In comparison, each concept in the Pugh chart scored negatively against last year's design. Regardless, the designs with best scores were rated in a decision matrix, which were the mesh tower, wide base tower, and triangular prism tower. The mesh tower was ruled out when advancing to the decision matrix due to its difficult manufacturing and compromised structural integrity (lack of solidity throughout the length of the tower). Using a decision matrix, it was determined that the wide base tower design and previous year's design were nearly tied after completing the ratings within the decision matrix. The design that overall won was the wide base design. This design is advantageous because of its lower drag and weight at the top of the tower, reducing the acting moments about the base of tower.

5.1.4 Yaw Design Selection

As part of the competition requirements, the turbine must implement a yawing mechanism. The yawing mechanism will direct the turbine into the wind to maximize the efficiency of the turbine. Our team is focusing on a passive yawing system. The passive yaw concepts that were generated were treated the same as the previous three subsystems. The Pugh chart for the yaw used the 2108 NAU yaw design as the datum, while five generated concepts were compared to it. The concepts that scored the highest in the Pugh Chart phase were the Pyramid (connected tip), Pyramid (separated tip), and Rough surface yaw concepts. Due to the high rating that these concepts scored, the decision matrix for the yaw system was used with the three highly rated concepts, rather than rating the previous year's yaw design. All three concepts scored nearly identically in the decision matrix. The design that the team will devote attention to is the Pyramid tip design. The yaw selection tools can be found in Appendix C.3 & C.4.

5.1.5 Shaft Design Selection

The shaft in our design must be strong and durable enough to handle a high number of cycles under multiple loading scenarios. Our overall system will contain a hub with connected blades, a swashplate, a braking rotor, a bearing, and a generator. Each of these listed items will be connected to the shaft in a different way, imparting a unique force at several different locations. The 2018 team created a shaft that can withstand these forces, and our concepts were evaluated with the many different factors considered. In the Pugh Chart, the 2018 design was the datum.

Our team had two concepts that were rated better than the other two that were considered in the decision matrix. The two best concepts generated were the polymer shaft and hollow shaft concepts, which both were negatively ranked in the Pugh chart phase, like the Pugh chart for the tower design selection. The shaft decision matrix showed that the most efficient and viable shaft was the 2018 design. Our team will focus on a design like this, with modifications to the shape. Due to its success in last year's competition, our advisor has expressed that a similar design would be a strong candidate for our design. The selection tools developed for selecting a strong shaft design can be found in Appendix C.5 & C.6.

5.2 Design Description

This section discusses the process the team used to develop designs for the selected concepts in section 5.1 that entail blade selection criteria that focuses on efficiency, compactness and other CRs. The brake selection leverages five concepts highlighted in 2018's designs that are then discussed against a datum. Lastly is the selection of the yaw and tower selection that primary aims to meet ERs and CRs as discussed above.

5.2.1 Blade Design

The blades are designed to implement multiple airfoils throughout the blade due to the varying operating conditions across the length of the blade. To quantify the several different operating conditions, the Reynold's number was calculated in two different operating scenarios, start-up and during operation. Prior to the calculation for Reynold's number, the geometry of the blade must be found. Calculating the geometry of blade involved creating a computer code that implemented the use of many equations from Manwell's *Wind Energy Explained* Chapter 3: Aerodynamics. The equations used to create the computer code and define a blade shape can be found below in equations 5.1 – 5.4. The equations include many variables such as (λ_r (tip-speed ratio), (ϕ) (angle of relative wind), c (chord length), and T (Twist angle relative to tip of blade).

$$\lambda_r = \lambda r R(i) \quad (5.1)$$

$$\phi(i) = \left(\frac{2}{3}\right) * \text{atan}\left(\frac{1}{\lambda_r(i)}\right) \quad (5.2)$$

$$c(i) = 2.25 * \frac{(8 * \pi i * r(i))}{BC_l} * (1 - \cos(\phi(i))) \quad (5.3)$$

$$\theta_p(i) = \phi(i) - \alpha \quad (5.4)$$

The equations shown above calculate the different variables that are essential to calculating the chord length and twist angle, c & T . After developing the geometry, equation 5.5 can be used to evaluate the Reynold's number operating environment for the blade.

$$Re_L = \frac{\rho UL}{\mu} \quad (5.5)$$

The two essential Reynold's number states for blade operation were calculated to be 3,433 and 63,396 as the start-up and operating environments, respectively. The NACA 8510 & NACA 9612 were chosen based on the Reynold's numbers to be implemented into the blade for optimum lift and drag effects.

5.2.2 Brake Design

The design selected for the first iteration of the brake system includes a linear actuator that presses a brake pad into a brake rotor disc. This system is compact, eliminating unnecessary space on the nacelle and making it lighter. Based on calculations done in the individual analysis, a linear actuator was found to be able to apply more clamping force on the brakes than other designs. The clamping force (CF) was calculated using equation 5.7.

$$CF = \pi * 2D * 4P \quad (5.6)$$

where D is the diameter of the rotor and P is the operating pressure from the linear actuator. Since that is a major role in stopping the wind turbine that design was chosen. Figure 5.1 below is the first iteration of the brake design assembly in SolidWorks.

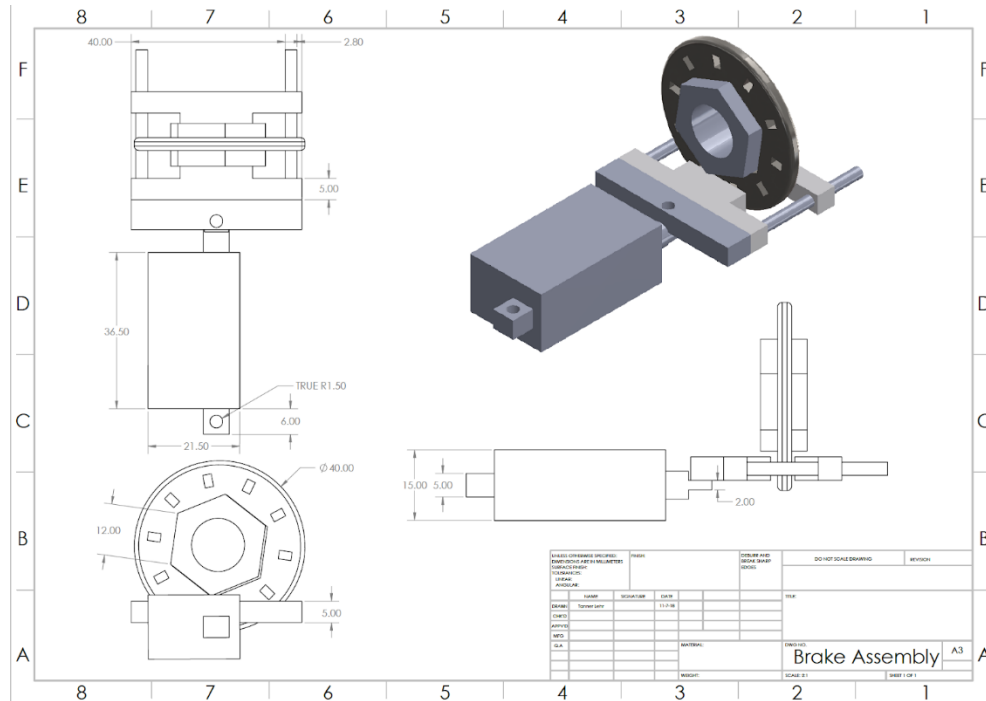

Figure 5.1 Brake Assembly

With the layout of the braking system seen in Figure 5.1, the brakes will be able to activate and deactivate easily without much error. The disc rotor fits onto the shaft hub loosely, which is called a floating brake design. This makes it so when the brake pad being actuated forward can rotate the rotor allowing it to press against the brake pad on the backside of the rotor.

5.2.3 Wide base Tower Design

This tower design is characterized as a cylinder with decreasing cross-sectional area as the tower extends from the base. This tower is stable under even high winds due to the decreasing surface area, leading to a decrease in drag force enacted on the tower. Also, another advantage is that the decreasing cross-sectional area helps to lower the center of gravity of the tower, leading to a more solid stability.

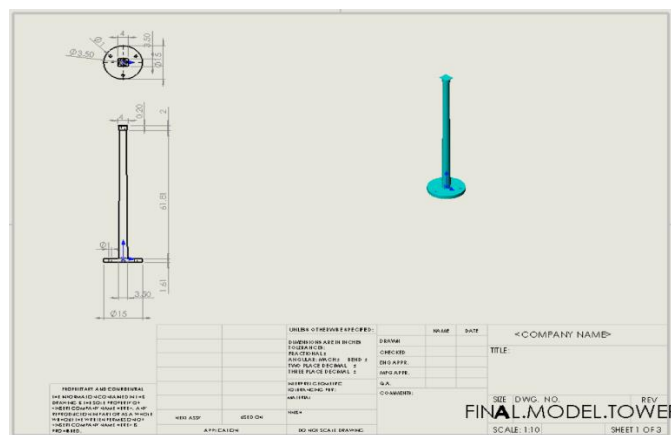

Figure 5.2 CAD Drawing of Tower

Mathematical Modeling of the tower

The von mises stress for the plane stress is expressed by use of the following equation [12]:

$$\sigma' = \sqrt{\sigma_x^2 - \sigma_x \sigma_y + \sigma_y^2 + 3\tau_{xy}^2} \quad 5.7$$

Where σ_x and σ_y are the normal stresses in the x and y plane respectively, while τ_{xy} is the shear stress in the xy -plane.

The normal strain is calculated using the following equation [12].

$$\epsilon = \frac{l - l_0}{l_0} \quad 5.8$$

Where l is the original length of the bar and l_0 is the change in length of the specimen. Furthermore, the factor of safety is defined as the ratio of the yield stress of the material to the allowable stress [12].

$$\text{Factor of Safety} = \frac{\sigma_y}{\sigma'} \quad 5.9$$

Where, σ_y is the yield stress of the material and σ' is the calculated Von Mises stress.

After conducting an analysis using the Solidworks simulation it is found out that this tower design can withstand 50 N-m bending force under 20 m/s air velocity without any deformation. The maximum von mises stress is 5.314×10^5 Pa and the minimum stress is zero. The maximum displacement is 2.794×10^{-3} mm and the minimum displacement is $.01 \times 10^{-3}$ mm. The maximum value of the strain is 2.331×10^{-6} . In addition, of the factor of safety was found to be 3.2×10^2 . To this end, the safety factor is within the suggested range, and is thee von Mises stress and displacement. The value obtained for the von Mises yield stress implies that the ductility of the tower will serve the structure without reaching a critical value that may cause failure.

5.2.4 Angled Yaw Design:

The selected design, which aligns to the preceding mathematical model and with a wide base as highlighted above, is a modified version of yaws that have been successful at the Collegiate Wind Competition in the past as well as successful yaw designs created by NAU's past teams. The design implements a triangular design to maximize torque around the tower due to the center of gravity being forced away from the axis of rotation as well as increasing the drag force imparted on the surface of the yaw. The wedge design of the yaw is a bit heavier than desired, so future iterations will see a focus on lightening the yaw while maintaining the advantages it currently has.

When the wind turbine operates in yaw, the average amount of power that is extracted an opposed to a situation whereby wind is perpendicular to the rotor plane. Yawing can lead to substantial cyclic gyroscopic loads. These loads are the largest on the blade roots and rotor shaft of small wind turbines and are represented by use of the following equation.

$$M = kN J \omega \quad (5.10)$$

Where M is the load(moment), kN is a numerical factor depending on the number of blades, J is the moment of inertia of the blade and ω is the yaw rate. This equation gives the maximum magnitude of the cyclic gyroscopic component.

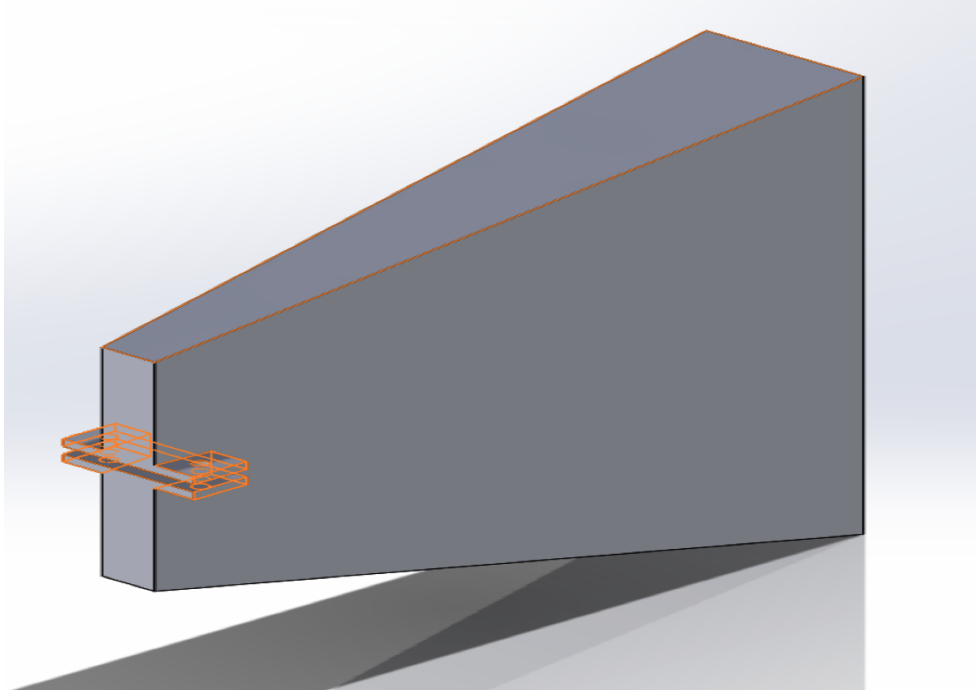

Figure 5.3 Isometric View of Yaw

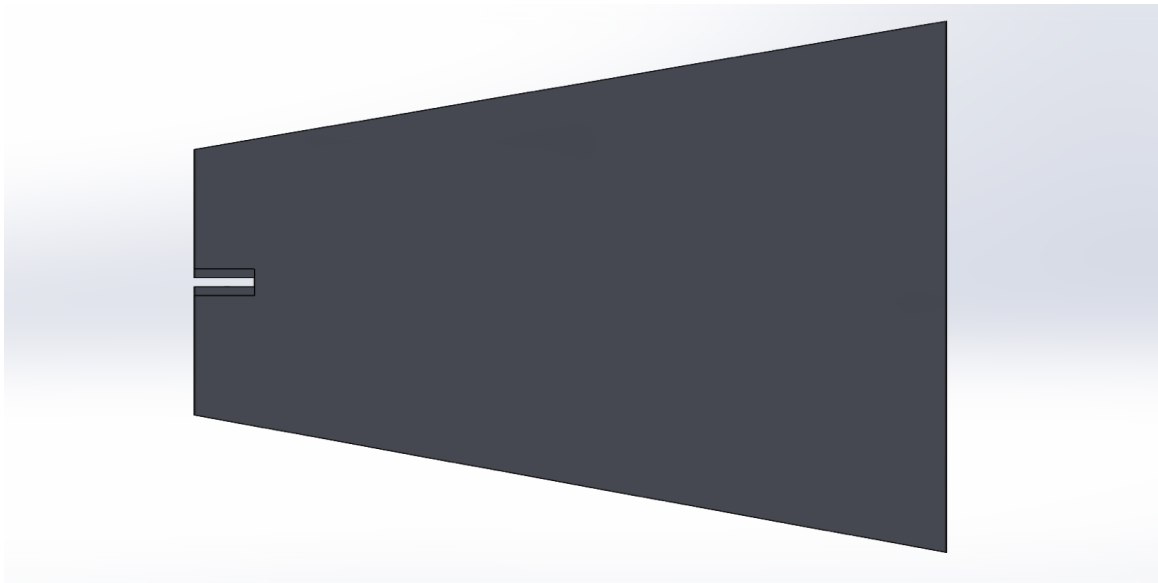

Figure 5.4: Side View of Yaw

5.2.5 Hollow Shaft Design

The hollow shaft design will decrease the weight of the shaft. By decreasing this weight, more mechanical energy can be devoted to spinning the generator. The shaft is ultimately a metallic tube that will be the connecting mechanism between the hub and the generator. This device must be designed to

achieve optimum efficiency while maintaining enough strength to withstand the torque enacted on the specimen throughout many cycles.

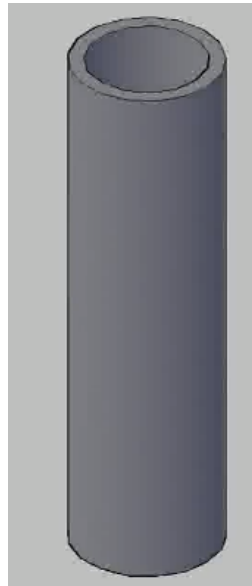

Figure 5.5 Hollow Shaft Design

Since the shaft will experience several unique loads, materials used to create the shaft should be durable, tough, and strong. To quantify the amount of stress the shaft will experience, many factors need to be considered. Using the equations below (Eq. 5.12 & 5.13), using shear and bending moment calculations from the variety of mounted components as the forces, the stress the shaft can withstand can be estimated.

Shafts exposed to twisting moment only are represented using the following equation

$$\tau = \frac{Tr}{J} \quad (5.12)$$

Where, T is torque (twisting moment), J is the polar moment of inertia of the shaft about the axis of rotation, τ is the torsional shear stress, and r is the radius of the shaft.

Maximum stress applied to the shaft is expressed by use of the following bending equation:

$$\sigma = \frac{My}{I} \quad (5.13)$$

Where, M_y is the bending moment, I is the moment of Inertia about the axis of rotation of the shaft's cross-sectional area, σ is the bending stress, and y is the distance from the center of the shaft.

The assessment is supported by several implementations. To begin with, when designing the system, the tower and the base must be reinforced to the ground using the hollow tunnel or shaft. It is, therefore, designed to be tall to allow the ease of securing the turbine on the ground. The hub should also be capable of securing the blades on the nacelle.

6 Proposed Design

Figure 6.1 below illustrates the current assembly of the proposed design. The proposed system has been developed by the team tasked for the project. While still subject to improvements and dimensional adjustments if advised, the system demonstrates few dimensional and illustrative errors that can be

rectified by performing more tests. Nevertheless, the CAD representation can be used to construct the wind turbine. One of the modifications of original design is the yaw, because the length from the nacelle needed to be decreased in order to fit within the volume restraint given by the project sponsor. To make up for the loss of length in the distance off the back of the turbine, the yaw was expanded in the vertical distance and the angle between the intercept of the two sides of the yaw design. The team was able to create a finished proposed design, shown in Figure 6.1. The design also shows how system components are interconnected.

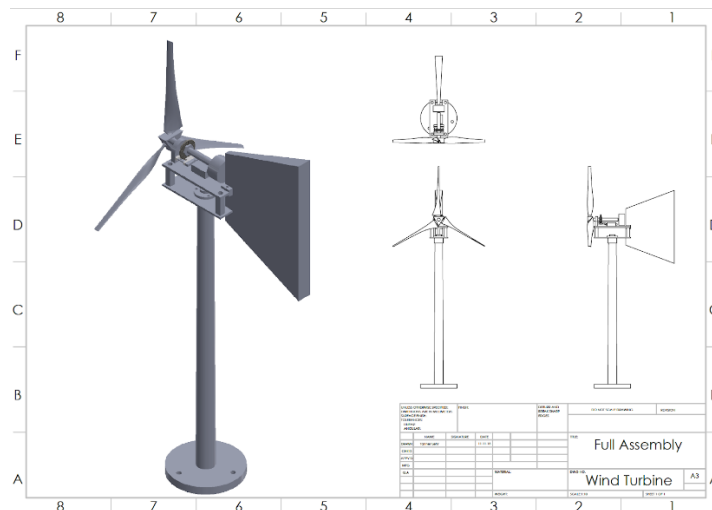

Figure 6.1 Wind Turbine Final Proposed Design

Based on the Final Proposal for the Wind Turbine a Bill of materials was created to show what parts would be needed and how much they cost. With all parts accounted for the total estimated cost to purchase all the necessary parts came out to be \$930.78, which can be seen in Table 6.1. As the project progresses, some parts may be added onto this list as well as taken off the list. The budget anticipated is below our budget target.

Table 6.1 CWC '19 Budget

	Part	Cost
Bought:	Blade 2B4:C630s Blade Swashplate	\$ 10.88
	4x8x3mm Rubber Shielded Ball Bearings	\$ 10.88
	EL-Kit-003 UNO Project Super Starter Kit	\$ 38.12
	Carbonx Fiber Reinforced Nylon	\$ 68.00
	1018 Steel Tubing: 1.5" OD, L=36"	\$ 61.56
	6061 Aluminum Tubing: 2.5" OD, L= 6"	\$ 12.10
	Retaining Rings 1.25"	\$ 6.83
	1.25" ID Bearings	\$ 26.72
	3/8" ID Bearings	\$ 26.67
	J-B Plastic Weld	\$ 10.14
	Push Button	\$ 12.59
	Disc Brake Pads	\$ 10.88
	Stepper Motor	\$ 17.86
	Servo Motor	\$ 19.95
	Linear Actuator	\$ 87.97
	6061 Aluminum Plates	\$ 35.00
	1018 Steel Plate	\$ -
	Aluminum Tubing Spacers	\$ -
	DH 8 channel Slip Ring	\$ 38.80
	8 Channel 10A Slip Ring	\$ 34.42
	Micro-Linear Actuator (x2)	\$ 161.61
	SunnySky X6215S kv: 170	\$ 81.37
	MAD5010 kv: 200	\$ 115.00
	Turnigy 5206 Gimbal Motor kv: 42	\$ 43.43
	Travel and Competition costs	N/A
	Total:	\$ 930.78

7 Design Objectives - Second Semester

For the 2019 Collegiate Wind Competition, Team NAU's design objective was to build the best wind turbine to compete in the competition. To make this happen the team decided to do multiple designs for each sub system to ensure everything was going to work for every single test. At this year's competition, the turbine is required to meet the following requirements:

- Maximum wind speeds up to 20 m/s
- Yaw rates of 180°/s
- Rotor and non-rotor parts fit into 45 cm x 45 cm x 45 cm box centered at 60 cm +/- 3cm
- 15 cm diameter cylinder from floor to box must contain non-rotor parts
- Electrical components can be outside of testing tunnel with no size restrictions
- Voltage must be DC and at the Point of Common Coupling (PCC) must be less than or equal to 48V
- Cut-in wind speed between 2.5 m/s to 5 m/s
- Noise higher than 100 Hz is filtered to prevent aliasing by the data acquisition system
- Electrical components must meet or exceed NEMA type 1 rating
- All electrical cables must have connectors and no individual strands
- Turbine must fit through a 61 cm x 122 cm door
- Mountable in a specific location in the wind tunnel
- Baseplate must withstand tension up to 50 N-m and be less than 16.1 mm thick
- Baseplate will be tied to earth ground and must have a 100 kΩ or less resistance
- Tested at 5 m/s to 11 m/s for a maximum of 60 seconds

7.1 Aerodynamics Design Objectives (Riley)

The team chose to implement a three-bladed upwind system for the 2019 CWC competition. Due to the generator testing that was completed by the team, it was apparent from the results that the cogging torque was higher than in previous NAU teams' generators. Overcoming this cogging torque at start-up is addressed by the team by increasing rotor solidity, to maximize torque produced by the rotor. The chord length was extended throughout the length of the blade to achieve the increased solidity while maintaining the integrity of the three-blade system. As this will be discussed with more detail in chapter 9.2, an active pitching mechanism was implemented to balance the high solidity of the rotor with the efficiency of the blades. Two airfoils are integrated into the blade design to optimize the lift and drag characteristics at each blade element as the blade extends from the axis of rotation.

An active pitching mechanism was incorporated into the design of the hub for the team's turbine. This mechanism was designed to mimic a helicopter's pitching mechanism, while also designing for ease of manufacturing the design. The hub was designed in such a way to minimize the hub diameter, to maximize the aerodynamically effective swept area. The use of this mechanism will allow the team to maintain operation in the proper range of attack angles for the selected airfoils, as to avoid the effect of aerodynamic hysteresis resulting from aerodynamic stall.

7.2 Brake Design Objectives (Tanner)

This year team NAU decided to go with a brake design that uses a linear actuator and a brake caliper that incorporates a bearing block for the shaft to run through. This design is a lot more intricate than previous NAU teams' brake designs because our brake calipers were designed and manufactured by our team rather than buying parts off the shelf. This allowed our team to adjust the design multiple times and not have to worry about the changes affecting another part of the design of the turbine.

The brakes are a crucial part of the wind turbine for this competition because there are two different brake tests that teams can take apart of. One brake test will be on command whereas the other will be when the wind turbine load is disconnected from the Point of Common Coupling (PCC). This brake design allows the team to compete without having to worry about the brakes failing during testing.

7.3 Structure Design Objectives (Tanner)

The structure of the wind turbine was designed to withstand the forces within the testing tunnel. The main concern when designing the structure is making sure that the tower does not deflect to ensure that the rotor remains normal to the flow. To accomplish this the team decided to go with 1018 steel because of its modulus of elasticity and strength characteristics. Also, the nacelle is an essential part of the structural design of the turbine because it houses the brakes, shaft, generator, rotor, and other electrical components. It is crucial to ensure everything will stay fastened with enough stability to maintain its rigidity.

7.4 Yaw Design Objectives (Riley)

The driving objective for the design of the yawing system was to minimize resistive torques while maintaining enough structural integrity to support the up-tower components of the turbine. Initially, the team devoted their focus to optimize the tail of the yawing system by maximizing surface area while also manipulating the design to move the center of mass of the tail away from the rotor. The team used this approach in designing the tail to maximize the angular momentum created by the tail to rotate about the tower. Further, a dual-bearing assembly was used in conjunction with the tower to mitigate resistive torques while connecting the nacelle to the base of the turbine. The design was guided by the competition stated requirement of achieving a yaw rate up to $180^\circ/\text{s}$ during testing.

8 Basic Static Performance (Not Included)

9 Analysis of Mechanical Loads

With the loads that are expected from the wind on the turbine, analysis was done to ensure failure due to stress on the blades, hub, shaft, brakes, tower, yaw, and nacelle would not happen. This was done using SolidWorks Simulations such as Finite Element Analysis (FEA) and hand calculations.

9.1 Blade Analysis (Riley)

The blade shape and structure was initially defined in MATLAB before importing the blade shape to Q-Blade's open source analysis software. While completing the initial analysis, the team addressed two scenarios that the blades would experience during testing, startup and operating conditions. The Reynold's numbers for these two scenarios were approximated at wind speeds of 5 m/s and 11 m/s, for startup and rated wind speed, respectively. Using an iterative process, the MATLAB script was modified in conjunction with *airfoiltools.com* data to determine the optimal operating range of attack angles for the selected airfoils. The selected airfoils chosen contained high-cambered characteristics to maximize lift under low-Reynold's number operating conditions.

Material selection for the turbine blades was completed by considering two primary concerns, deflection and stress. In accordance with these concerns, the team sought to find a material that achieved high strength and high elastic modulus, that can be created using a 3D printer. After careful consideration, the team selected a carbon-fiber reinforced nylon filament to manufacture the blades.

Following the material selection process, the design was evaluated in SolidWorks Simulation module provided by NAU to students. The finite element analysis(FEA) that was completed for the blades considered two forces, lift and centrifugal force during operation. To achieve a factor of safety in the most extreme condition, the team calculated these forces at a wind speed of 20 m/s at a tip-speed ratio of 5. Using the maximum wind speed allows the team to simulate the highest stress conditions experienced by the blade. Additionally, the fixture for the blade includes a single shoulder bolt through the root of the blade to maintain its position in blade root housing portion of the hub. In figure 9.1, the results of the FEA simulation for the blade are shown. The analysis was completed at an angular velocity of 588.24 rad/s, and a distributed lift force of 250 N.

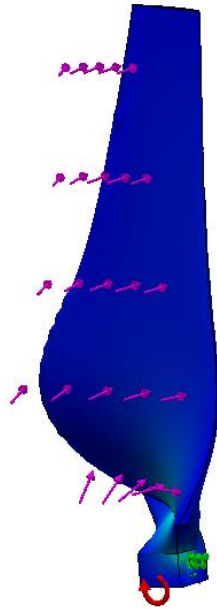

Figure 9.1 Blade FEA

The analysis performed validated that the team's blade will not fail under the loading conditions stated above. The factor of safety for the blade is approximately 3.5. The stress concentrations surrounding the shoulder bolt used to fix the blade to the hub is cause for concern, but will not cause failure in the blade throughout operation of the turbine.

9.2 Hub Analysis (Riley)

An active pitching mechanism was developed to control the angle of attack of the blade to avoid reaching stall during operation. As mentioned in chapter 7.2, the hub was designed to mimic a helicopter pitching mechanism. The designed hub consists of two main parts, the triangular main hub and hub "claws" that are built to house the root of the blade. Due to the nature of the design, stress concentrations occur within in the design(s) as shown in figure 9.2 and figure 9.3.

Similar to chapter 9.1, the hub and hub claw were analyzed in SolidWorks Simulation module. Due to its ease of manufacturability, the team selected 6061 aluminum to create the hub design. The hub is connected to the claws via a countersunk bolt in combination with a thrust bearing and nut. A countersunk bolt was chosen to maintain a low profile beneath the root of the blade. The hub and hub claw were both simulated at 20 m/s, to simulate the highest forces that the mechanism would experience. It was assumed that drag forces would be negligible for the hub and hub claw, and therefore the only acting force on the mechanism was the centrifugal force due to the high speeds of the rotor at 20 m/s.

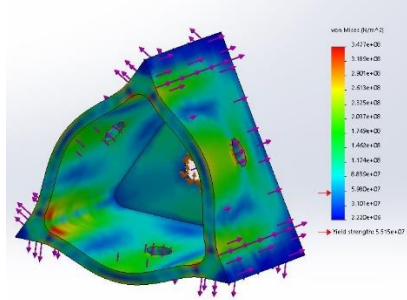

Figure 9.2 Hub Stress FEA

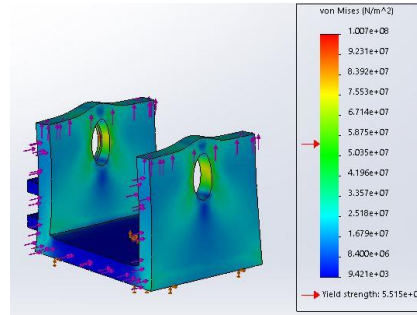

Figure 9.3 Hub Claw FEA

9.3 Shaft Analysis (Naser)

This section entails the design process of a key and keyway system for mounting the turbine rotor. The joint was designed to connect the rotor hub and the generator shaft. Different types of keys were considered from which the square key was selected. In summary, the section outlines the design procedure and analysis of the key and keyway for hub-shaft joint connecting the rotor assembly and generator shaft. The maximum torque transmitted based on the shaft specifications and safety factor was 9.7223 Nm. The designed width and length of the key were 2.38 and 170 mm respectively. The cross-section area, therefore, was specified as . Using the area, the shear stress acting on the key was given as and the design compressive stress two times the value . From the Machinery's Handbook, it was identified that square keyway of 3 mm by 3 mm would be appropriate and standard. An allowance of 0.01 mm between the key and keyway was recommended for fitting the key.

$$\tau_{xy} = \frac{Tr}{J} \quad (9.1)$$

$$\tau_{max} = \pm \sqrt{\tau_{xy}^2 + \left(\frac{\sigma_x}{2}\right)^2} \quad (9.2)$$

$$W = \frac{HS_C}{2S_s} \quad (9.3)$$

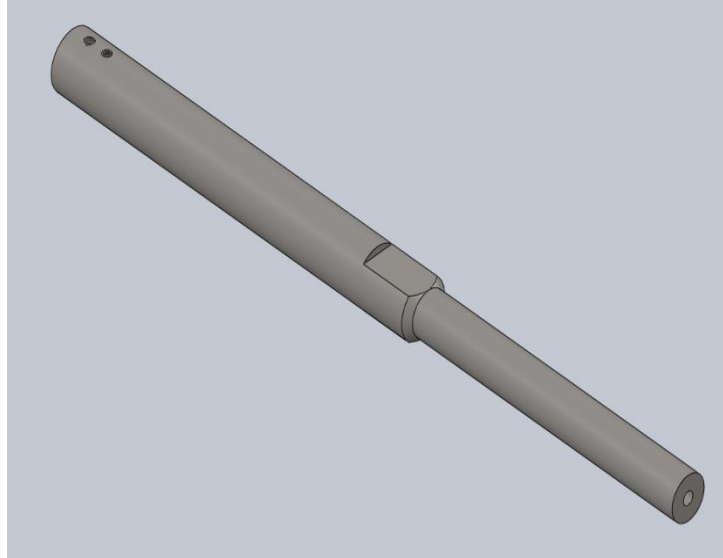

Figure 9.4 Shaft

9.4 Brake Analysis (Tanner)

To make sure the brake system would be able to stop the rotor in a reasonable time and withstand the forces produced when initiating the brake system. The brake calipers and rotor were made using 6061-T6 Aluminum. This makes it so a good portion of force can be applied to brake and failure due to stress and torsion will not occur. The amount of clamping force and braking torque on the brakes can be calculated by using the following equations:

$$CF = \frac{\pi D^2 P}{4} \quad (9.4)$$

$$BT = \left(\frac{D}{2}\right) (2\mu * CF) \quad (9.5)$$

With those equations the clamping force was estimated at 60 N and the braking torque was estimated at 7 Nm. By utilizing SolidWorks FEA each component of the brakes was analyzed with the expected force and torque parameters. In figures 9.2-9.4 below, the factors of safety can be seen.

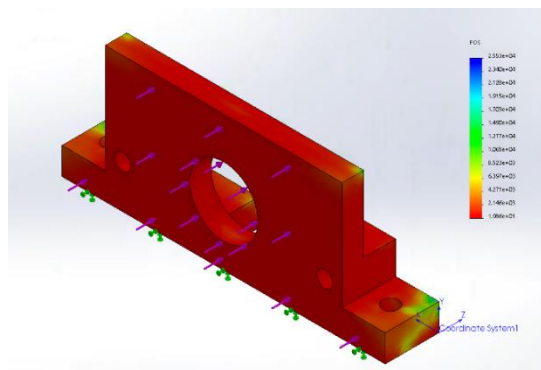

Figure 9.5 Front Brake Caliper FEA

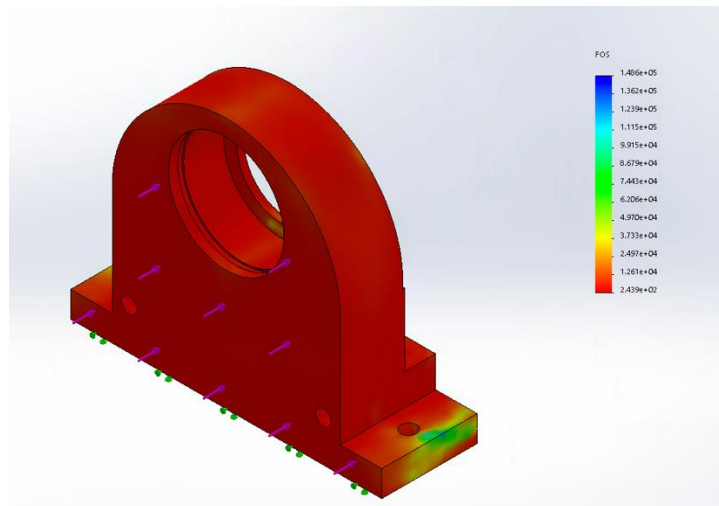

Figure 9.6 Back Brake Caliper FEA

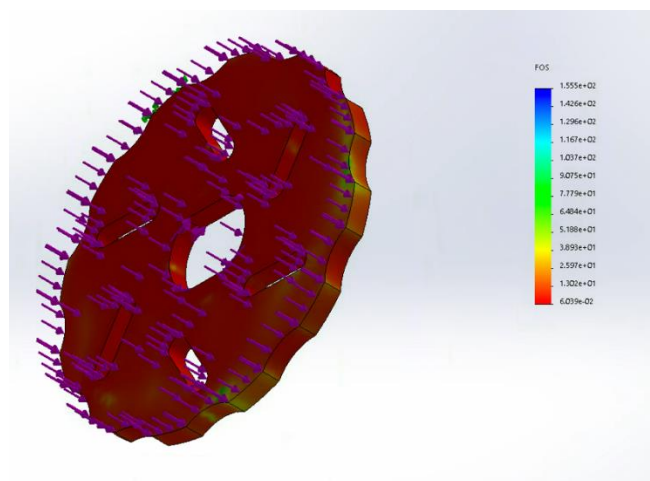

Figure 9.7 Brake Disc FEA

The factors of safety for both brake calipers and brake rotor withstand all forces that are present during testing.

9.5 Tower Analysis (Tanner)

During testing the tower must be able to withstand thrust and mechanical loads that are being applied on the system. In order to make sure the tower can withstand this; the thrust loads were analyzed at the top of the tower to make sure the stress concentrations and deflection is minimized. The tower was machined from a 1018 Steel tube, this was chosen because it has a yield strength of $3.5 \times 10^8 \text{ N/m}^2$ and it can be manufactured easy. Below in figure 9.5, the factors of safety are shown. With the same amount of force being applied the maximum deflection is 0.289mm and the maximum stress $3.3 \times 10^6 \text{ N/m}^2$.

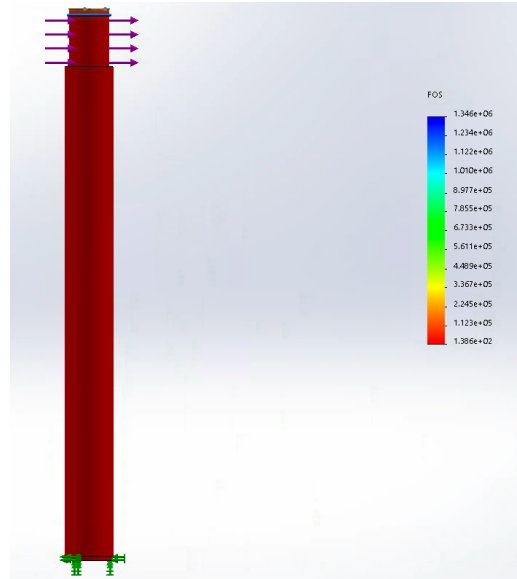

Figure 9.8 Tower FEA

9.6 Yaw Analysis (Faisal)

The yaw design approach entails several design elements. For instance, the design can be a dragonfly design system, which, while lacking a yawing mechanism, leverages a horizontal axis turbine at its end and rotates perpendicularly relative to the orientation of a secondary turbine. Secondly, a Robert Howell design uses a vertical axis, hence does not require yaw. It, however, captures wind energy from a variety of angles. Lastly, a MagLev design captures wind energy from all angles, proving more reliable than the preceding systems.

The safety factor for any yawing mechanism depends on how it works. Before looking into the safety factors that come with the yawing mechanism, we took some time to understand the functionality of the yawing system. It is paramount to understand the functionality so as to ensure that the specific elements of the system are functioning well. For this particular project, the wind turbine was designed in such a way that the system can regulate the amount of energy input despite the amount of wind drive input that the wind turbine is exposed to. This functionality was achieved by minimizing the rotor swept area that is directly facing the oncoming wind blast. For rapid power modulations, yaw speed must be set higher as the power produced by the turbine gradually decreases. Errors associated with the yaw rate of the wind turbine system are also minimized in the process. Since our focus relies on how much such errors can be avoided to increase the efficiency of the wind turbine system, it was tuned to acquire such functionality (Hansen 79). In this case, the efficiency of the wind turbine depends solely on the yaw velocities. It was simple to calculate the amount of yaw and the yaw speeds on a two-blade rotor. For our two-blade wind turbine rotor the speed was set to around 10 m/s which was different to the conventional 0.5 m/s. Another advantage that comes with the two-blade rotor is that it can distribute the weight or rather reduce it with the help of the yawing system thus protecting the wind turbine from extreme destructive loads called fatigue loads (Nikolić et al 262). The incorporation of some hydraulic yaw drives can enable the yawing system to withstand fatigue load destruction whereby damping the yaw system via these drives. Driving the wind turbine out of the direct wind may also lead to a subsequent reduction of these extreme and fatigue loads.

$$D = C_d * \frac{\rho V^2}{2} \quad (9.6)$$

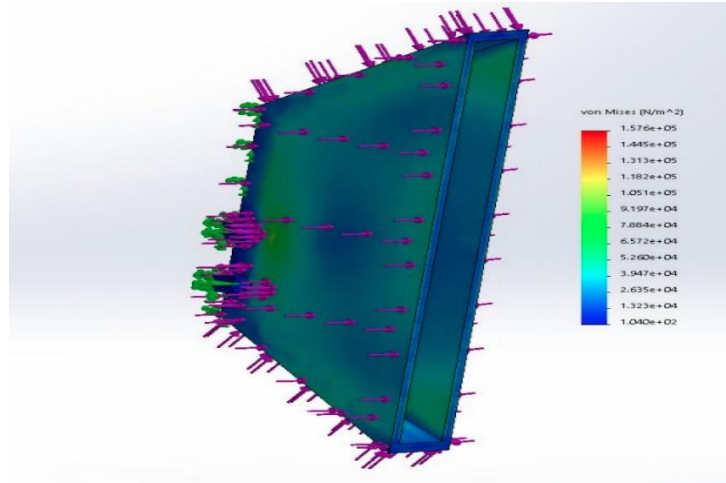

Figure 9.9 Tail FEA Analysis

9.7 Nacelle Analysis(Tanner)

The nacelle was designed to be aerodynamic and allow all mechanical and electrical components needed up tower to have enough space. To make sure the design could also withstand the forces that are going to be in the wind tunnel, 6061-T6 aluminum was used. This allows the turbine to be light weight but also be rigid. Everything is held together by using aluminum spacers and steel bolts. With the force due to the wind in the tunnel, the nacelle can expect to see a maximum stress of 2.25 N/m² and a maximum deformation of 0.0056mm. The factor of safety on the nacelle can be seen below in figure 9.7.

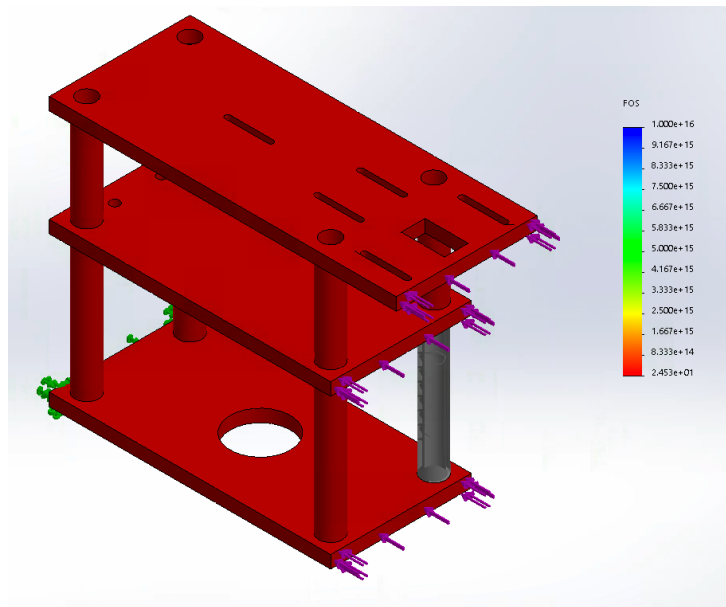

Figure 9.10 Nacelle FEA

10 REFERENCES

- [1] Northern Arizona University, "Wind Turbine Technical Report," U.S. Department of Energy, Flagstaff, 2017.
- [2] Pennsylvania State University, "2017 Department of Energy Collegiate Wind Competition," US Department of Energy, 2017.
- [3] Northern Arizona University, "NAU Collegiate Wind Competition 2017-2018," U.S. Department of Energy, Flagstaff, 2018.
- [4] ABM Greiffenberger, "ABM Greiffenberger Antriebstechnik GmbH," 2018. [Online]. Available: http://www.abm-antriebe.de/2413_abm_greiffenberger_introduces_new_drive_solutions_for_wind_turbines.html. [Accessed 20 October 2018].
- [5] Bonfiglioli, "700 TW-Wind Turbine Yaw Control gear motor," Bonfiglioli, 2018. [Online]. Available: <https://www.bonfiglioli.com.au/en-au/wind/products/gearmotor-gearboxes-for-wind-turbines/product/700tw-wind-turbine-yaw-control-gear-motor>. [Accessed 20 October 2018].
- [6] Bonfiglioli, "700T series-Wind Turbine gear motors," Bonfiglioli, 2018. [Online]. Available: <https://www.bonfiglioli.com.au/en-au/wind/products/gearmotor-gearboxes-for-wind-turbines/product/700t-series-wind>. [Accessed 20 October 2018].
- [7] J. D. a. W. Giewont, "Dynamic Brake Control". United States of America Patent 4761600, 2 August 1988.
- [8] "Wind-Turbine-Shaft (HS-0018)," Made-in-China, 2018. [Online]. Available: <https://hshengmic1015.en.made-in-china.com/product/FKCEHRzOZxVY/China-Wind-Turbine-Shaft-HS-0018-.html>. [Accessed 19 October 2018].
- [9] "Wind Turbine Rotor Shaft-Guoguang," Calendering machine, 2018. [Online]. Available: <http://calenderingmachine.com/4-2-wind-power-turbine-shaft.html>. . [Accessed 19 October 2018].
- [10] "Turbines installed on 120 meter high hybrid towers," 2013. [Online]. Available: <http://www.nordex-online.com/en/products-services/hybrid-towers.html>.
- [11] J. Manwell, *Wind Energy Explained*, West Sussex, United Kingdom: John Wiley & Sons Ltd., 2002.
- [12] R. G. Budynas and J. K. Nisbett, *Shigley's Mechanical Engineering Design* 10th edition, New York, New York, USA: McGraw-Hill Education, 2015.
- [13] C. Levandowski, "Lib.dr.iastate.edu," 2018. [Online]. Available: https://lib.dr.iastate.edu/cgi/viewcontent.cgi?article=1116&context=undergradresearch_symposium. [Accessed 20 October 2018].
- [14] D. A. a. J. Veigh, *Wind Turbine Materials and Manufacturing Fact Sheet*, Princeton: Princeton Energy Resources International, 2001.
- [15] J. S. Strong, "Design of a Small Wind Turbine," 2008.
- [16] Collegiate Wind Competition "Project Information 2017" N.p. 2017
www.cefn.s.nau.edu/capstone/projects/ME/2017/CollegiateWindComp/ Accessed 4 Mar 2019

11 APPENDICES

11.1 Appendix A: House of Quality

Minimize Cost												Legend				
Volume(45x45x45)	-											A	17	NAU		
Cut-in Speed(2.5-5)	-											B	18	NAU		
Yaw Rate(up to 180)												C	17	PSU		
Area (61x122)	+	++										Down =	D			
Yield Strength	-		+	+								Up =	U			
Number of Cycles to Failure	-		-													
Weight	-	+		-												
Assembly Time																
		Engineering Characteristics										Benchmarking				
Improvement Direction		D	D	D	U	N/A	U	U	D	D						
Units		\$	cm ³	m/s	°/s	cm ²	Ksi	\$	lb	min						
Customer Needs	Customer Weights	Minimize Cost	Volume(45x45x45)	Cut-in Speed(2.5-5)	Yaw Rate(up to 180)	Area (61x122)	Yield Strength	Number of Cycles to Failure	Weight	Assembly Time	1 Poor	2	3 Acceptable	4	5 Excellent	
Cost Effective	5	3				3	3	1	3	3				C	AB	
Compact	5	1	3			3		1	3	3					ABC	
Optimize Efficiency	4	3		3	3	1		1						AB	C	
Effective Direction mechanism	5			1	3		1	1						B	A C	
Easy Start up	5			3	1	1									AB C	
Strong	3	3		1	1		3	3	3						AC B	
Durable	3	3		1		1	3	3	3	3					AC B	
Lightweight	2	3					3	3	3					B	AC	
Portable	2		3			3		1	3	3					ABC	
Raw Score		86	51	92	89	78	80	63	72	57					688	
Relative Weight %		12.87%	7.63%	13.77%	13.32%	11.60%	11.98%	9.43%	10.78%	8.53%					100%	
Rank Order		3	3	1	2	5	4	7	6	8						

11.2 Appendix B: Designs Considered

Appendix A.1: Linear Actuator Brake

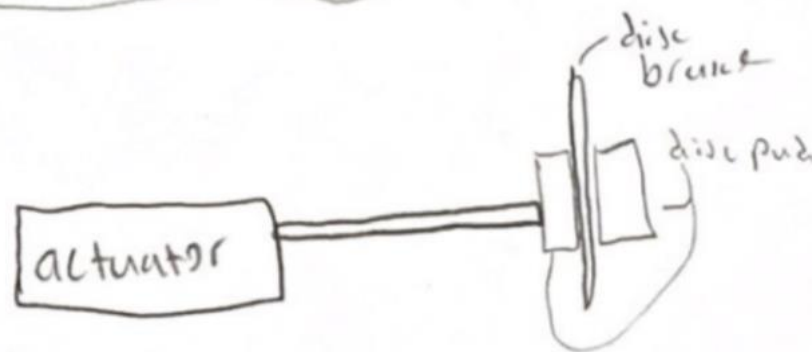

Appendix B.2: Wide Base Blade Concept

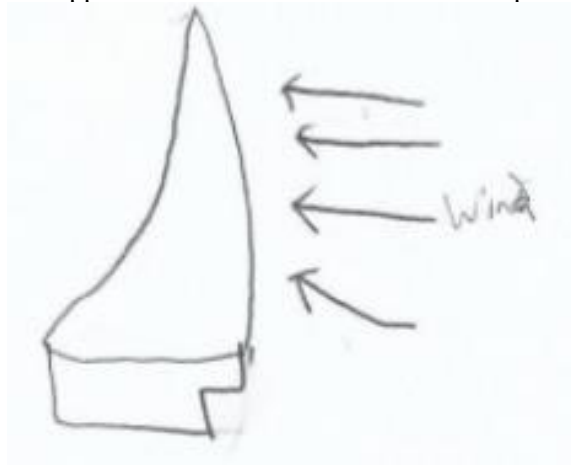

Appendix B.3: Rolly Chair tower design

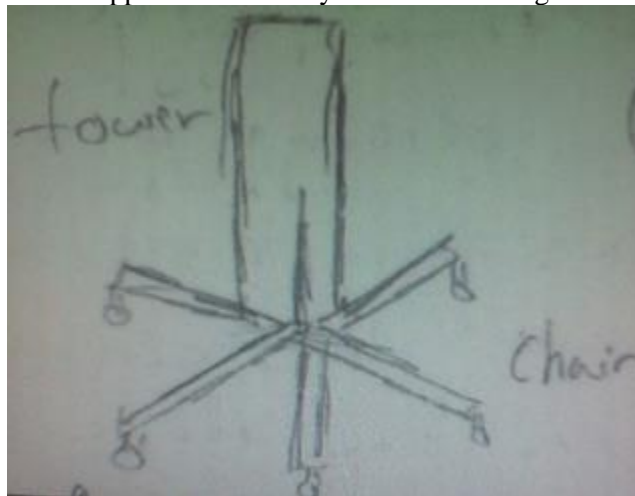

Appendix B.4: Yaw Incorporated Tower



Appendix B.5: Thick Diameter End Shaft



11.3 Appendix C: Designs Selected

Appendix C.1: Tower Pugh Chart

		Tower					
		CWC '18	Triangle	Rolly Chair	Tower Yaw	Wide Base	Mesh
Concept		DATUM	1	3	4	5	6
Criteria							
Cost Effective			-	-	-	-	-
Optimize efficiency				-	+		+
Compact			-	-	-	-	
Low Cut-in					+		
Strong			+	-	-	+	-
Durable			+	-	-	+	-
Lightweight				+	-	-	+
Portable/ease of assembly			-	-	-	-	
# of +'s			2	1	2	2	2
# of -'s			3	6	6	4	3
Sum			-1	-5	-4	-2	-1

Appendix C.2: Tower Decision Matrix

		Tower Design					
		Triangle		CWC'18		Wide Base	
Criteria	Weight(%)	Score	Weighted Score	Score	Weighted Score	Score	Weighted Score
Cost Effective	12.87%	40	5.148	70	9.009	65	8.3655
Optimize efficiency	7.63%	50	3.815	65	4.9595	60	4.578
Compact	13.77%	50	6.885	50	6.885	50	6.885
Low Cut-in	13.32%	50	6.66	50	6.66	50	6.66
Strong	11.68%	70	8.176	65	7.592	75	8.76
Durable	11.80%	70	8.26	65	7.67	70	8.26
Lightweight	9.43%	55	5.1865	65	6.1295	60	5.658
Portable/ease of assembly	10.70%	50	5.35	50	5.35	50	5.35
		SUM=	49.4805	SUM=	54.255	SUM=	54.5165

Appendix C.3: Yaw Pugh Chart

		Yaw					
		CWC '18	Pyramid(tip)	Pyramid(separate)	Rough Surface	Tower Yaw	Active
Concept	DATUM		2	3	4	5	1
Criteria							
Cost Effective					+	-	-
Optimize efficiency			+	+	+	-	+
Compact			+	+	+	+	+
Low Cut-in							
Strong			+	+		+	
Durable							-
Lightweight			+	+	+	-	-
Portable/ease of assembly			+	+	+	+	-
# of +'s			5	5	5	3	2
# of -'s			0	0	0	3	4
Sum			5	5	5	0	-2

Appendix C.4: Yaw Decision Matrix

		Yaw					
		Pyramid(Tip connection)		Pyramid(Separated tip)		Rough Surface	
Criteria	Weight(%)	Score	Weighted Score	Score	Weighted Score	Score	Weighted Score
Cost Effective	12.87%	50	6.435	50	6.435	65	8.3655
Optimize efficiency	7.63%	70	5.341	70	5.341	65	4.9595
Surface Area normal to flow	13.77%	65	8.9505	65	8.9505	50	6.885
Yaw Rate (Torque)	13.32%	70	9.324	70	9.324	60	7.992
Strong	11.68%	70	8.176	70	8.176	60	7.008
Durable	11.80%	70	8.26	70	8.26	60	7.08
Lightweight	9.43%	40	3.772	40	3.772	70	6.601
Portable/ease of assembly	10.70%	45	4.815	50	5.35	50	5.35
		SUM=	55.0735	SUM=	55.6085	SUM=	54.241

Appendix C.5: Shaft Pugh Chart

		Shafts				
		CWC 18	Thick Ends	Polymer	Plain	Hollow
Concept		DATUM	2	3	4	1
Criteria						
Cost Effective				+	-	-
Optimize efficiency			-	-	-	+
Compact						
Low Cut-in			-		-	-
Strong			+	-	+	
Durable				-	+	-
Lightweight			-	+	-	+
Portable/ease of assembly						
# of +'s			1	2	2	2
# of -'s			3	3	4	3
Sum			-2	-1	-2	-1

Appendix C.6: Shaft Decision Matrix

		Shaft Design					
Criteria	Weight(%)	Hollow		CWC'18		Polymer	
		Score	Weighted Score	Score	Weighted Score	Score	Weighted Score
Cost Effective	12.87%	40	5.148	60	7.722	50	6.435
Optimize efficiency	7.63%	60	4.578	65	4.9595	45	3.4335
Compact	13.77%	50	6.885	50	6.885	65	8.9505
Low Cut-in	13.32%	65	8.658	60	7.992	70	9.324
Strong	11.68%	50	5.84	60	7.008	40	4.672
Durable	11.80%	50	5.9	60	7.08	40	4.72
Lightweight	9.43%	65	6.1295	55	5.1865	70	6.601
Portable/ease of assembly	10.70%	50	5.35	50	5.35	50	5.35
		SUM=	48.4885	SUM=	52.183	SUM=	49.486